

Insulated Panel Systems  
North America

# Installation Guide

## KS Series Commercial & Industrial Wall Panels

Optimo<sup>®</sup>, Azteco<sup>™</sup>, Granitstone<sup>®</sup>, Mini-Wave, Mini Micro-Rib, Micro-Rib, Shadowline

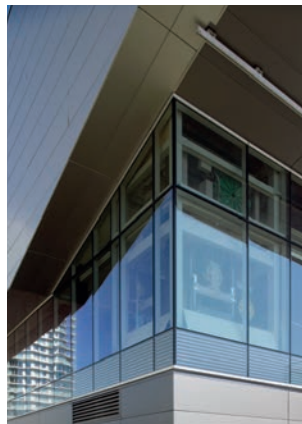

# Contents

01

## Installation Procedure

Introduction	3
Technical Information	5
Inspection Upon Delivery	6
Panel Handling	7
Panel Storage on Site	12
Handling and Storage of Items and Accessories	13
Removal of Protective Film	13
Structural Steel Framing	14
Panel Cutting Procedures	14
Sealant Placement	16
Panel Touch-Up Paint	17
Panel Cleaning and Maintenance	17

02

## Installation

Vertical Panel Installation	18
Fastener Information	28
Vertical Construction Details	29
Horizontal Panel Installation	48
Horizontal Construction Details	63

03

## Miscellaneous

Materials, Tools and Hardware	87
-------------------------------	----

### Disclaimer

This installation guide is only to be used in conjunction with panel installation drawings and Kingspan recommended details. Details shown in project shop drawings take precedence over any similar information in this manual. Shop drawings may be prepared either by Kingspan or by the panel contractor. Kingspan Technical Service Department is available to assist the panel contractor in the review of shop drawings.

This guide is intended to provide the panel contractor with recommended methods, procedures and guidelines for the installation of the KS Series wall systems for commercial / industrial and architectural applications. Information presented is accurate but may not cover all situations, building conditions and / or details of your specific project. Consult Kingspan Technical Services where this guide does not cover your unique construction requirements. It is the sole responsibility of the project engineer and panel installer to ensure specified air and weather tightness of a building by good design and workmanship in accordance with approved drawings using only the appropriate type of sealants. It is the sole responsibility of the owner's representative and panel installer to maintain quality workmanship in accordance with approved shop drawings to ensure the best performance of the wall system. Kingspan recommends installers read this document fully before receiving the panels on the job site. Installation classes are available through Kingspan's Technical Services Department. Please call 1-877-638-3266 for more information.

Follow the architect's approved shop drawings and engineering calculations for your project specific fastening patterns. The engineer of record is responsible for verifying applicable design loads and panel fastening requirements.

All safety procedures, including adequate fall protection, are the responsibility of the panel contractor.

### IMPORTANT!

Please read all information related to your project before receiving materials at the job site and before starting the installation.

# 1 Introduction

## 1.1 Features

Welcome to Kingspan, global leaders in the design and manufacture of insulated metal panels. Insulated panels serve as energy efficient, state-of-the-art alternative to traditional construction. This document serves as installation guidelines for the KS Series wall panel systems.

The KS Series product range is suitable for large scale industrial and commercial applications where both vertical and horizontal panels are required. The product set varies from 42" vertical panels with a Shadowline profile to a high end flat smooth 24" Optimo® profile.

1. Single component wall panels provide exterior weather barrier, insulating core and interior vapor barrier all-in-one
2. Unique side joint clip system eliminates the need for exposed fasteners
3. Panels are lightweight, easy to install under most weather conditions
4. Wide variety of profiles and textures provide architecturally appealing solutions
5. Panels are available in lengths of up to 52' to minimize the number of stack joints required
6. Accessory items including metal flashings and aluminum extrusions are also available (contact Kingspan for more information).

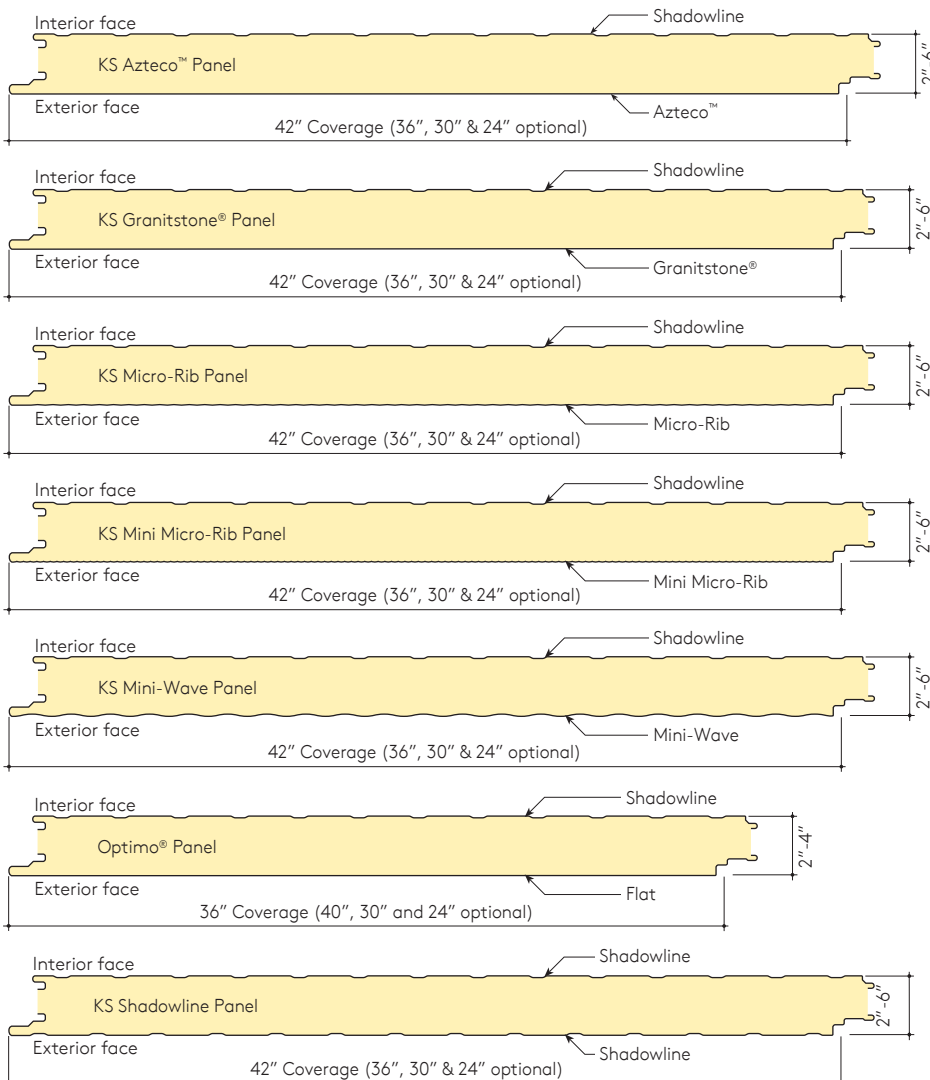

# 1 Introduction

---

## 1.2 Insulation Values

KS Series panels are available in the following configurations:

Thermal Performance at 75°F			Thermal Performance at 35°F		
Thickness	K-Factor	R-Value	Thickness	K-Factor	R-Value
2	0.07	14.4	2	0.06	16
2.5	0.06	18.0	2.5	0.05	20
3	0.05	21.6	3	0.04	24
4	0.03	28.8	4	0.03	32
5	0.03	36.0	5	0.03	40
6	0.02	43.2	6	0.02	48

KS Series panels offer the building designer R values of approximately 7.2 per inch Nominal, as well as the ability to balance initial cost versus long-term energy savings.

To complete the wall system a full range of integrated accessories including attachment clips, metal trims and aluminum extrusions are available.

---

## 1.3 Warranties

Kingspan can furnish various performance warranties as required by project specifications.

The items covered by these warranties include weathertightness, corrosion, structural performance and finish performance.

Weathertight warranties require the use of Kingspan Authorized Installers. In addition, these projects require several jobsite inspections, so be sure to schedule inspections in advance.

Kingspan requires that all specifications and shop drawings are reviewed prior to warranty issuance.

In addition, warranties are limited to materials supplied by Kingspan, and are not issued until full payment for all services and material provided is received.

Contact Kingspan Customer Service for more information on our warranty programs.

## 1.4 Installer Qualifications

Kingspan recommends that our panels are installed under the direct supervision of an experienced sheet metal craftsman trained in the proper application of our products. Please contact Kingspan at 1-877-638-3266 for information regarding our Authorized Installer training programs.

Kingspan KS Series wall panels have been thoroughly evaluated and tested by independent third party laboratories (UL, ULC, Factory Mutual etc.) to determine all aspects of their performance. The results of these tests, in combination with our comprehensive engineering analysis, enable us to provide design assistance for nearly every project. This includes complete panel analysis of wind, live, seismic and thermal loading as well as allowable spans, deflection and recommended fastening.

---

## 2 Technical Information

---

### 2.1 Deflection

Current International Building Codes specify wall cladding to be designed for a deflection of L/180. The project designer and /or engineer of record should always check the applicable code(s) for deflection limits. For deflection limits other than L/180, please contact Kingspan Technical Services for evaluation.

Kingspan panels have been evaluated by Factory Mutual and are in compliance with FM 4881 Approval Standard for Exterior Wall Construction.

For more information on any of the above items, please contact Kingspan Technical Services:

Deland, FL – 877-638-3266

Modesto, CA – 800-377-5110

Caledon, Ontario (Canada) – 866-442-3594

For installation assistance:

[installation@kingspanpanels.com](mailto:installation@kingspanpanels.com)

For engineering assistance:

[technical.NA@kingspanpanels.com](mailto:technical.NA@kingspanpanels.com)

The information contained in this guide is thought to be reliable and correct, but is subject to change without notice.

---

### 2.2 Panel Diaphragm

Insulated panels should NOT be relied upon to provide significant diaphragm strength. Instead, cross bracing (cables, rods, angle iron etc.) should be used to provide diaphragm. Insufficient bracing for the walls may result in damage to the panels, and will void the panel warranty.

---

### 2.3 Seismic

Kingspan wall panels are mechanically attached on one side only, with the other side free to slide along the tongue and groove joint configuration. In addition to this built-in slip joint design, the panels are very light (approx. 3-4 psf). As a result, they are ideal for use in seismically sensitive projects.

---

### 2.4 Fire Ratings

Kingspan panels have been thoroughly evaluated by Factory Mutual, UL and ULC and are covered under various product approval listings.

---

### 2.5 Air and Water Infiltration

Air and Water Infiltration testing has been successfully conducted on the KS Series panels in accordance with ASTM E-283/331.

## 3 Inspection upon Delivery

---

Panels are carefully packaged in large shrink-wrapped bundles, then shipped on flat bed trailers to the construction site. When a shipment is received, check all items against the shipping document for quantities, dimensions, colors, transit damage, etc. Document any shortage of panels and accessories or panel damage on the bill of lading and have it signed by the driver. It is the receiver's responsibility to make any damage claims immediately, and without report, it is implied that product was received in full and without damage.

Please note that although every effort is made to prevent shipping damage, Kingspan is not responsible for damage which may occur during transportation, delivery, storage or on-site handling. Photos taken of damaged panels while on the truck will help facilitate your claim with the shipping company.

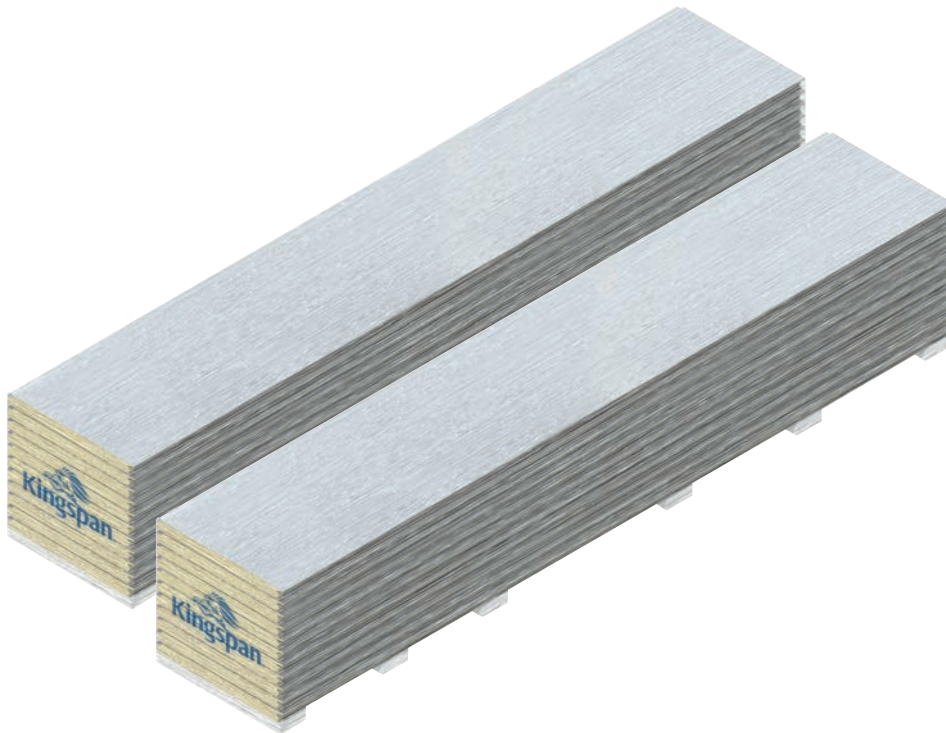

## 4 Panel Handling

### 4.1 Panels Handled by Forklift

**4.1.1** The recommended loading / unloading method for bundles less than or equal to 30' is to use a single forklift with widely spaced forks placed under the center of the bundle as shown in Figure 4.1a. Panel bundles over 30' in length may be moved by using two forklifts spaced equally along the length of the bundle as shown in Figure 4.1b. Inspect travel route to assure a reasonable level and compacted surface free of ruts and excavations.

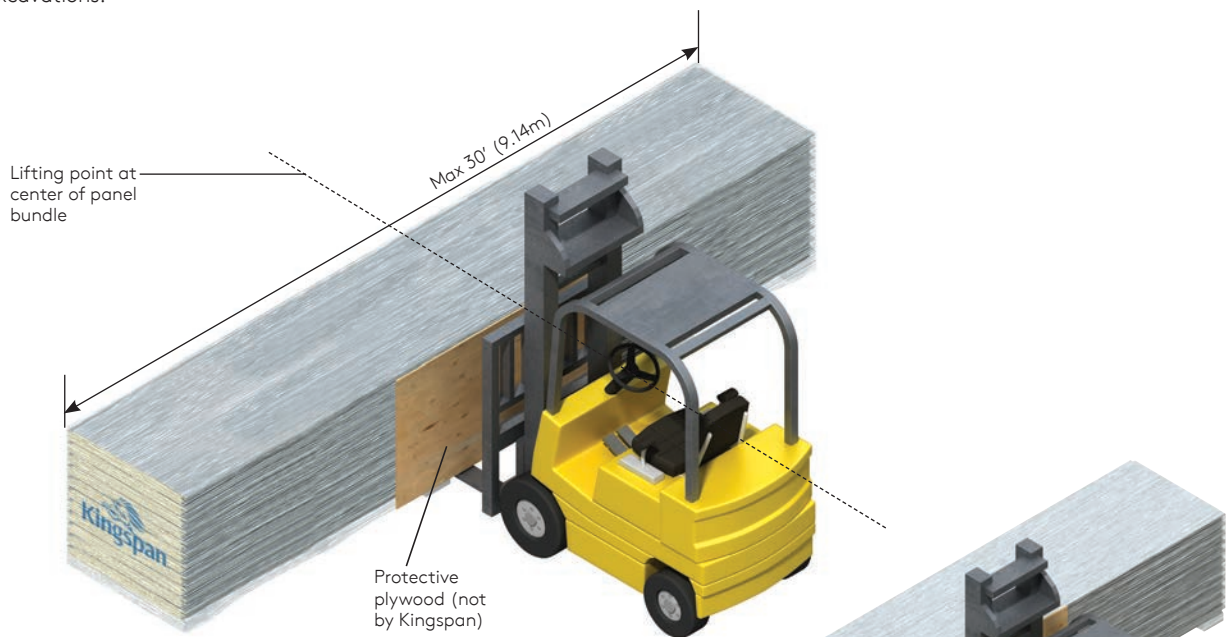

Fig. 4.1a

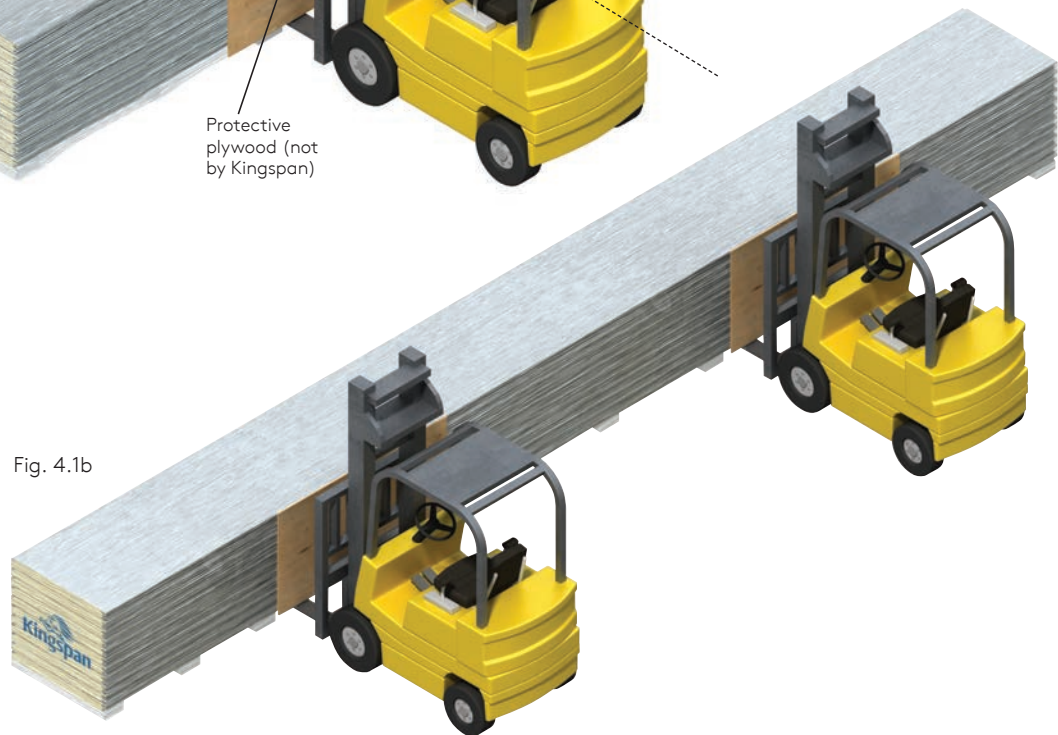

Fig. 4.1b





# 4 Panel Handling

4.2.3 When lifting bundles with a crane longer than 30' (9.14m), three points of support are required from lifting beam to bundle, as shown in Fig. 4.4. To prevent damage from nylon straps, use wood spreaders at top and bottom at lifting locations as shown in Fig. 4.4 and Fig. 4.5.

Fig. 4.4

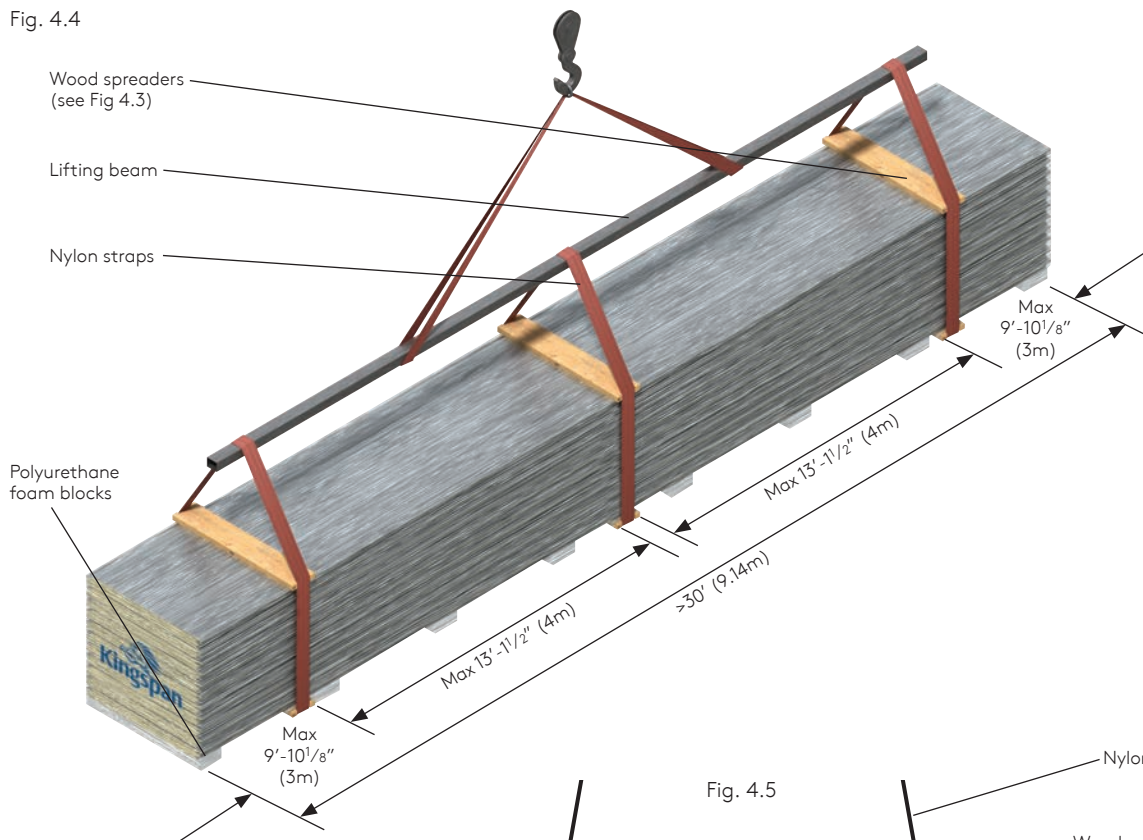
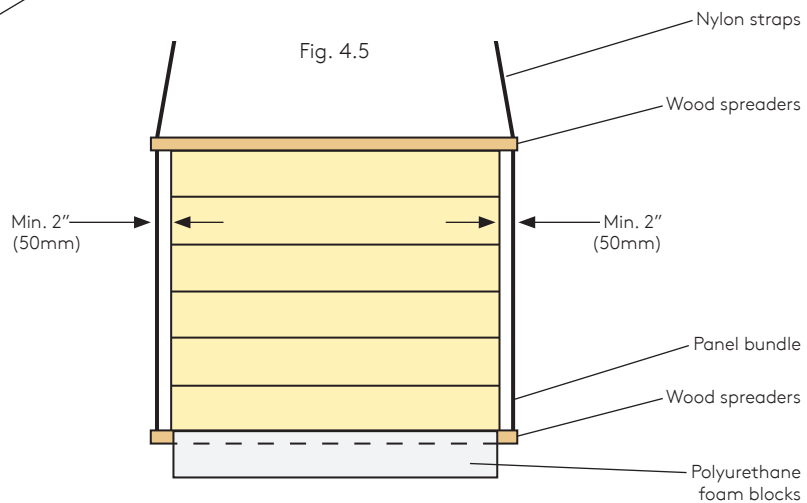

Fig. 4.5



# 4 Panel Handling

## 4.3 Handling Individual Panels

**CAUTION**  
4.3.1 Workers must wear appropriate protective gear at all times when handling panels. Failure to do so may cause injury.

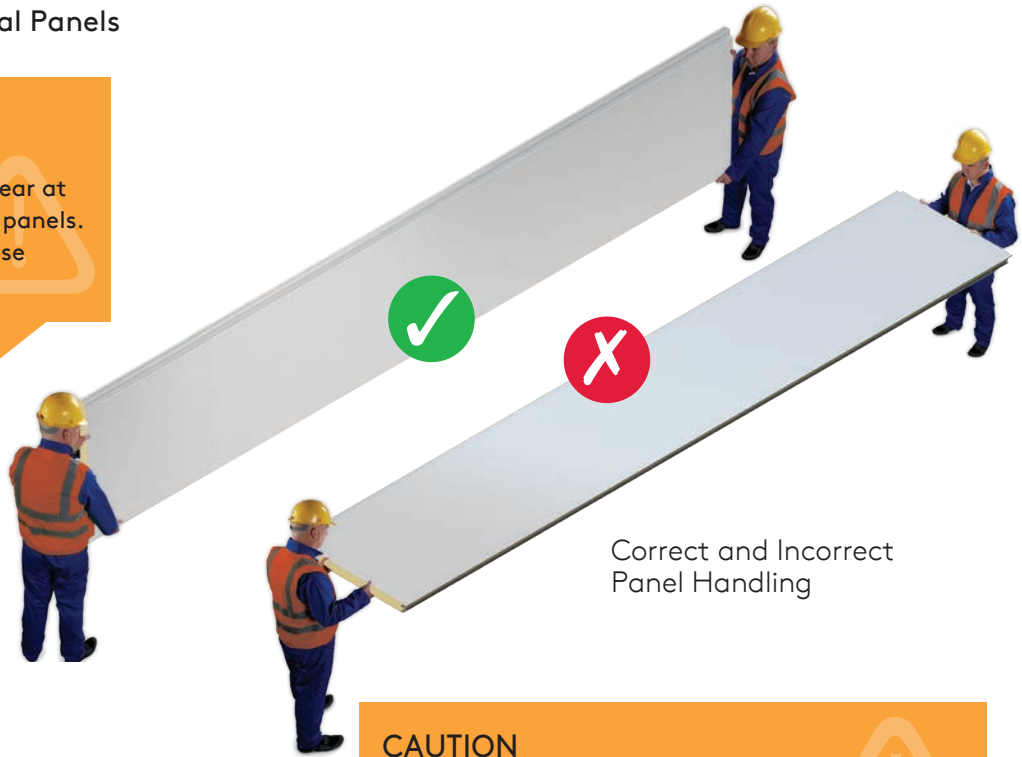

### Thermal Bowing

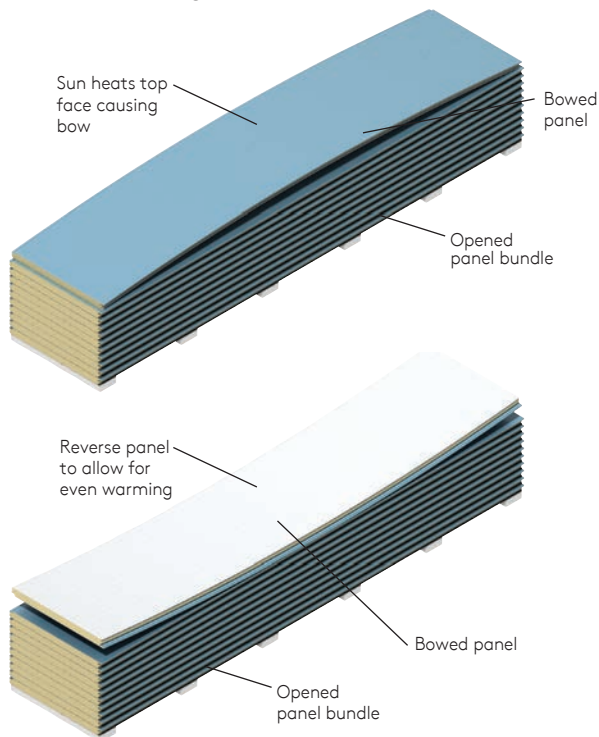

**CAUTION**  
4.3.2 Individual panels should never be moved in a flat position as excessive flexing may result. Excessive flexing ruptures a panel's core, permanently distorts the facings and may lead to thermal blistering. When moving a panel, it must be turned on its edge first, then supported at each end with as many men as necessary to safely handle.

**NOTE**  
Panels exposed to direct sunlight may exhibit thermal bow, which can hinder panel engagement. This can be corrected by either placing the panels in a shaded area, or by flipping the panels over exposing the cool side of the panel to the sunlight for approximately 15 minutes.  
Panels are to be fastened at every support unless otherwise indicated on the shop drawings. Fastener requirements at each clip are based on design loads. Refer to the shop drawings for the correct fastening, or contact Kingspan Technical Services for assistance.

## 4 Panel Handling

### CAUTION

4.3.3 To prevent joint damage and possible delamination, never lift a panel from the top sheet only. Lift from underneath the entire panel.

### CAUTION

4.3.4 Never drag a panel from a bundle or across other surfaces. It will scratch and damage the panel coating/finish. Always lift panels when removing from bundle.

### 4.4 Panels Lifting using Vacuum Equipment

Panel installation time can often be reduced by using vacuum lifting equipment. The following items need to be verified by the equipment supplier prior to use: lifting equipment must be adequate for panel lengths and weights, and provide sufficient mobility and reach for the project conditions.

Vacuum heads (cups) must be suitable to safely lift panels with profiled and /or embossed surfaces. Fluted profiles may require specific vacuum heads.

Kingspan recommends using Rotaboy and Cladboy vacuum lifting systems. For equipment parameters and availability, please contact:

AutoMak Assembly Inc. at 1-219-310-8458 /

info@automakassembly.com.vacuum lifting systems.



## 5 Panel Storage on Site

### 5.1

Site must have adequate storage space to receive and store the panel bundles. This space must be level, firm, clean and free from standing water. Bundles should be stored in a dry condition, with one end slightly elevated to facilitate moisture drainage.

### 5.2

Panels should be inspected upon delivery for presence of moisture. If moisture is present, bundles should be slit open immediately to allow ventilation and drainage, slits should be approx. 12" intermittently placed near the bottom of the wrapped bundle.

### 5.3

If panels are to be used immediately, bundles should be placed at pre-planned strategic locations around the building perimeter, as close as possible to the specific work areas. Review installation shop drawings to determine the best locations.

### 5.4

Panels in opened bundles should be covered by a plastic sheet or tarp at the end of the working day. The covering and bundles must be securely fastened to prevent wind damage (see Figure 5.1).

### 5.5

Granitestone panels exposed to site dust may exhibit a perceived tint variation when placed next to a clean panel. This effect is preventable if protected from dust accumulation and is not cause for rejection of the panel or claim against color match. Dust type may affect ease of cleaning, and may require multiple cleanings or time to fully weather in. Only use prescribed cleaning products and methods see section 12 for cleaning instructions.

### 5.6

When handling panels and / or panel bundles, ropes, steel cables or chains must not be used.

### 5.7

Avoid outdoor storing for longer than 60 days. Moisture between panels can cause corrosion or staining. Staining of any kind is not considered to be a cause for rejection.

### 5.8

If panels are not to be used immediately, then they should be stored under a temporary shelter with the plastic removed from the top and sides of the bundles. Recover the bundles with a protective tarp and adequately secure both tarp and panels to prevent wind damage (see Figure 5.1).

#### NOTE

When stacking bundles (maximum two high) limit storage time to 30 days to prevent panel damage.

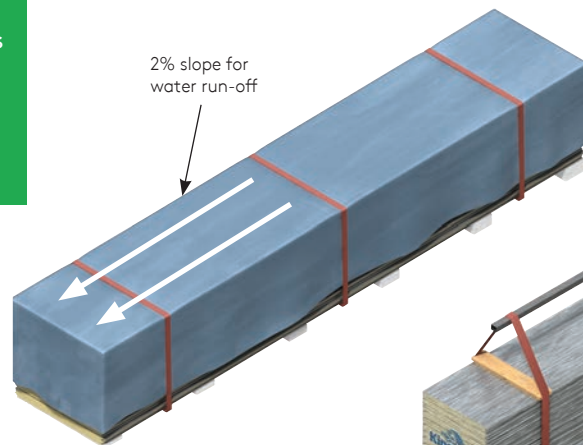

Fig. 5.1

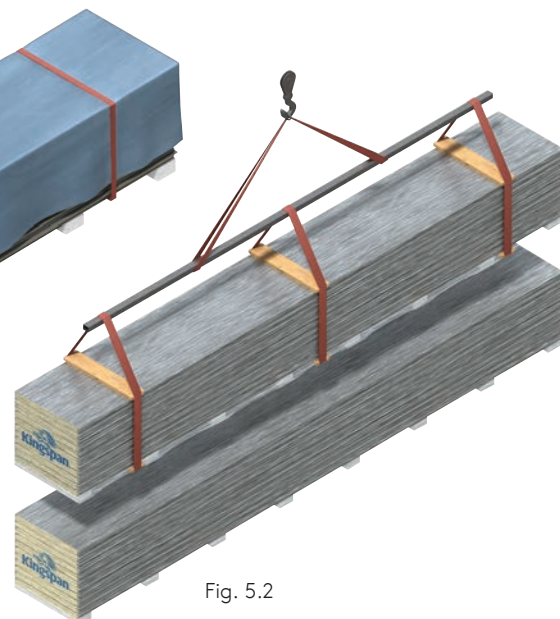

Fig. 5.2

## 6 Handling and Storage of Items and Accessories

### 6.1

Care should be taken during unloading and storage to prevent damage to small items, ie. trims fasteners, clips, sealants, etc.

### 6.2

Cover all pallet crates or boxes to protect materials from weather but allow for ventilation to prevent condensation. Temperature sensitive items such as butyl tapes and sealants should be stored under controlled conditions to maintain suitable application characteristics.

## 7 Removal of Protective Film

### 7.1

#### IMPORTANT!

If panels will not be installed within 60 days of receipt, the bundles should be unstacked and the protective film removed from each panel. Carefully restack the panels and protect from the elements. Failure to remove the film within this time period may result in excessive film adhesion and breakdown of the plastic, making removal extremely difficult. In addition, failure to remove the film as instructed may result in a buildup of adhesive residue.

Kingspan is not responsible for either of these conditions. Film removal and panel cleaning is the responsibility of the installation contractor.

### 7.2

It is recommended to remove protective film as panels are installed. Film on installed panels should be removed by the end of each day.

### 7.3

Loosen film along male edge and peel it off and down at approximately 45° angle from both sides of panels (see Fig. 7.1).

### 7.4

If adhesive residue remains on panel surfaces after the protective film is removed, panels may be cleaned with a rag soaked in Oil-flo 141 409, SFR or equivalent. After cleaning, rinse thoroughly. For safety, provide adequate eye and skin protection, ventilation and follow all other manufacturer's instructions.

### 7.5

Care should be taken when cleaning panels, the amount of force and time spent rubbing the surface can result in a polishing effect on the panel's surface. You should always trial methods and products in an inconspicuous area first.

Fig 7.1

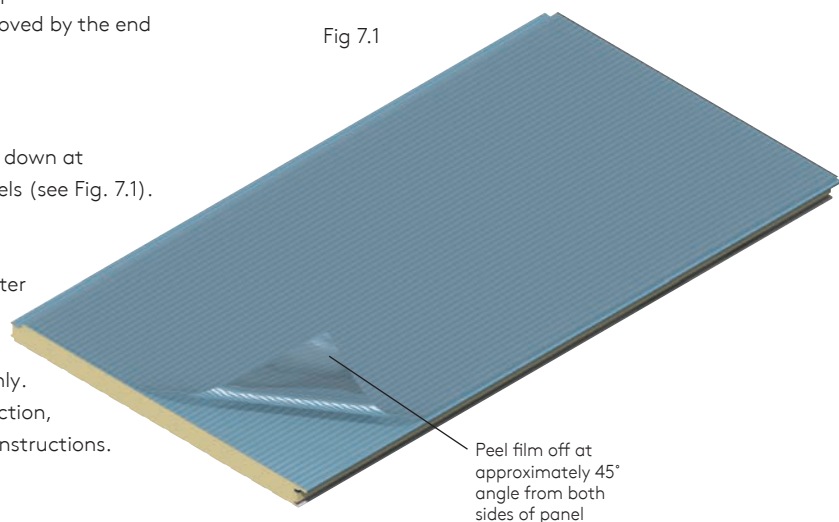

## 8 Structural Steel Framing

---

### 8.1

Review shop drawings prior to installation to verify that structural members are in the correct location.

### 8.2

Installer must examine the alignment of the structural steel before installation of the wall panels.

The walls must be square, and support members to which panels are attached must be in the same plane, flat and free of obstructions such as weld marks, bolts or screw heads.

For vertically installed panels, support members shall be:

- a. Plus or minus  $\frac{1}{8}$ " (3.17 mm) in 5 feet (1524 mm) in any direction along plane of framing
- b. Plus or minus  $\frac{3}{8}$ " (9.525 mm) in 20 feet (6096 mm) cumulative in any direction along plane of framing
- c. Plus or minus  $\frac{3}{4}$ " (19.05 mm) from framing plane on any elevation. Panel supports must extend to the outer extremities at all panel terminations.

### 8.3

For horizontally installed panels, support members shall be:

- a. Plus or minus  $\frac{1}{8}$ " (3.17 mm) in 5 feet (1524 mm) in any direction along plane of framing
- b. Plus or minus  $\frac{1}{4}$ " (6.35 mm) in 20 feet (6096 mm) cumulative in any direction along plane of framing
- c. Plus or minus  $\frac{1}{2}$ " (12.7 mm) from framing plane on any elevation. Panel supports must extend to the outer extremities at all panel terminations.

Any variance from tolerances can affect both performance and aesthetics and must be reported to the architect and general contractor, and corrected by the responsible party before panel installation begins.

## 9 Panel Cutting Procedures

---

### 9.1

Personnel working with panel cutting equipment should wear respiratory and eye protection at all times.

### 9.2

Panel cutting should take place prior to panel installation whenever possible.

### 9.3

Use the appropriate cutting tools with extreme care to avoid panel delamination. Do not use a cutting disk, torch, and other high heat producing methods for cutting. Hot filings may damage the painted surface of the panel. Kingspan recommends use of a circular saw with a fine tooth carbide tip blade (40 tooth minimum). A band saw with a suitable metal cutting blade may also be used.

### 9.4

For small penetrations, a Dremel type router may be used to cut each face of the panel, and a serrated bread knife may be used to cut the foam core.

### 9.5

Power snips, nibblers or hand snips may be used to cut trims and flashings.

## 9 Panel Cutting Procedures

### NOTE

Do not use an electric grinder, reciprocating saw, or any tool that may cause serious delamination which affects aesthetics, performance and panel warranty.



### 9.6

**Step 1:** Mark the cut line on the interior and exterior panel facings.

**Step 2:** Leave protective film in place during cutting. If film has already been removed, apply masking tape adjacent to the area to be cut.

**Step 3:** Recheck measurements and proceed with cutting operation. Cut the interior face of the panel and about  $\frac{1}{4}$  of the foam thickness using a circular saw with a fine toothed carbide tipped blade. Then carefully turn panel over and cut the exterior face and the remainder of the foam.

**Step 4:** For panels located at framed opening locations where 50% or more of the panel width is removed, cut interior face and foam to a depth of approx.  $\frac{1}{4}$ ". Flip panel over and cut exterior face and foam to a depth of approx.  $\frac{1}{4}$ ". Then cut through the joints on the edge of the panel that is to be removed for the opening. Lift the panel into place, secure with fasteners as required, then use a serrated bread knife to fully cut through the foam and remove the cut section of panel.

**Step 5:** File or sand off any burrs or rough spots at the cut line. Sweep off all metal shavings etc. Best practices include use of touch up paint on any cut edge. The panel is now ready to be erected.

Fig. 9.1

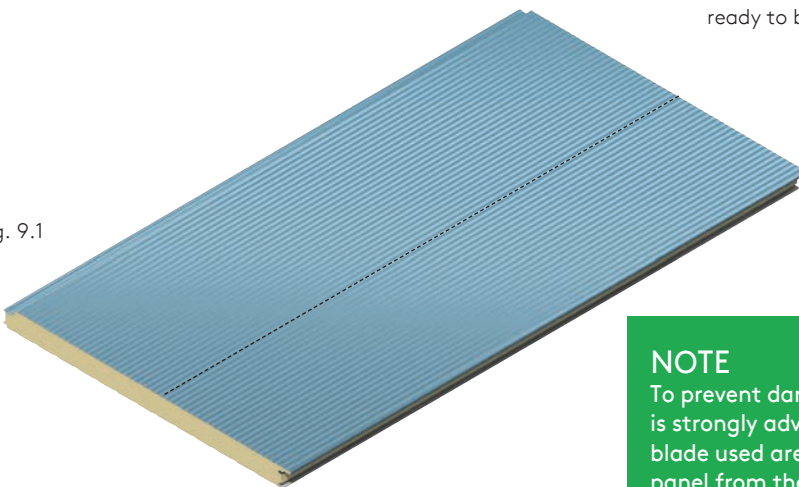

### NOTE

To prevent damage to Granitstone® finish panels, it is strongly advised that the saw and carbide tipped blade used are large enough to cut through the entire panel from the liner side only, except as noted in step 4 above.

## 10 Sealant Placement

### 10.1

Apply butyl sealant to interior female joint to ensure proper vapor barrier. Joint should be dry and clean before applying sealant. Fill female pocket approximately  $\frac{1}{2}$  to  $\frac{3}{4}$  full. Add / delete as necessary during panel installation to maintain proper panel seal.

Applying sealant on site (Fig. 10.1).

#### NOTE

Pull (not push) caulk tube along length of side joint for more uniform sealant bead.

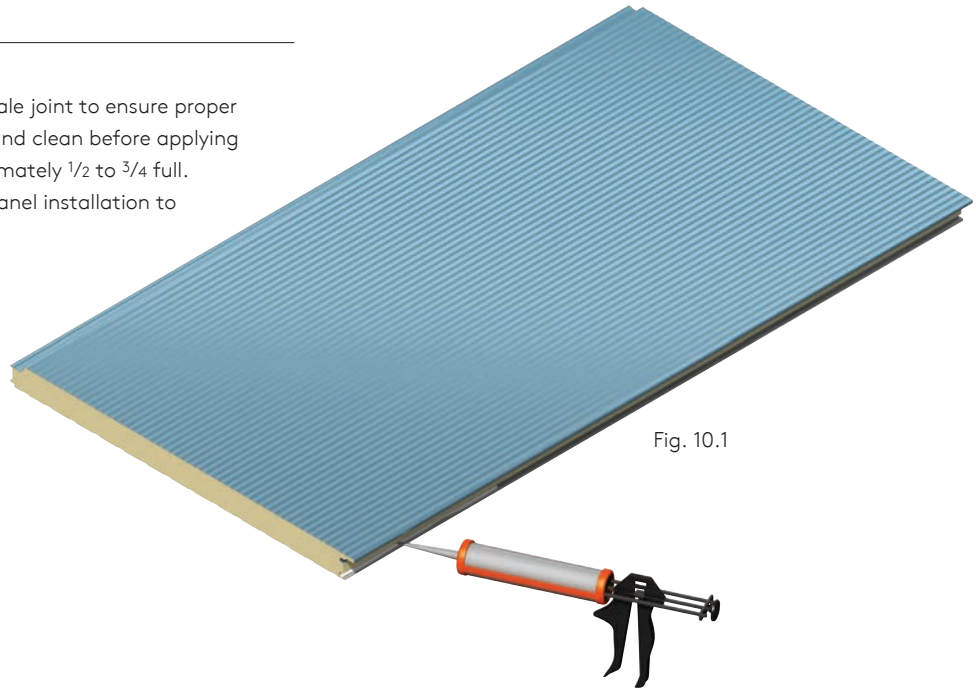

Fig. 10.1

#### NOTE

In extreme cold weather locations, it may be advisable to caulk both interior and exterior joints. It is also advisable to keep sealants in a warming bin until ready for use to ensure proper viscosity. Contact Kingspan Technical Services for more information.

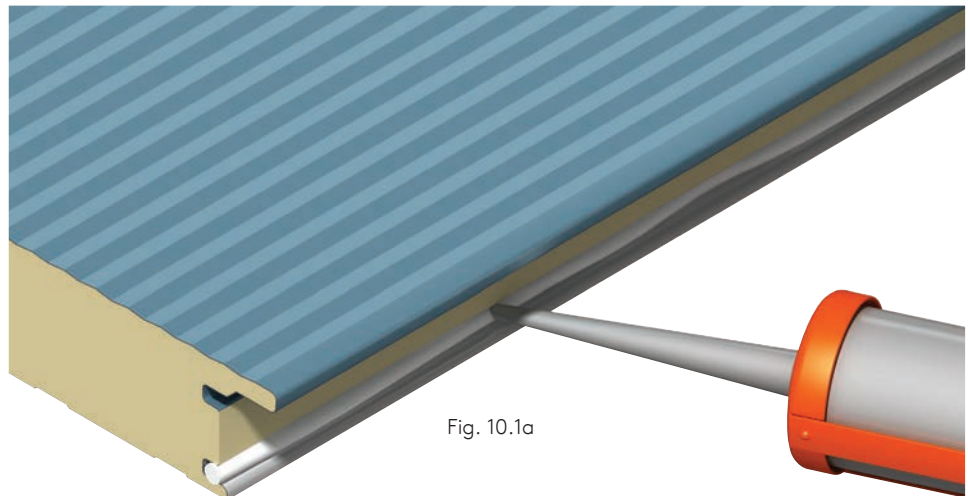

Fig. 10.1a



# 11 Panel Touch-up Paint

## 11.1

The panel erector is to touch up all exposed field cut edges with touch up paint. Contact Kingspan Customer Service for information on appropriate touch up paint.

# 12 Panel Cleaning and Maintenance

## 12.1

Proper installation and maintenance are extremely important in obtaining the very best service and appearance from pre-painted metal insulated panels.

## 12.2

All dirt, oil, grease, fingerprints, metal filings or other contaminants should be removed to assure proper service life of the paint system. The installer should wipe-down the panels as they are erected.

## 12.3

Dirt pickup may cause apparent discoloration of the paint after prolonged exposure. Slight chalking from strong sunlight exposure may also cause a change in appearance. A thorough cleaning will usually restore the original appearance of the panels.

## 12.4

In many cases, a simple low pressure wash of the building with plain water will be adequate. In areas of heavy dirt deposits, a solution of water and detergent (1/3 cup liquid Tide per gallon of water) may be used. Use a rag, sponge, or soft bristle brush to clean. A clean water rinse should follow.

## 12.5

Mildew may occur in areas subjected to high humidity. To remove mildew, use the following solution followed with a clear water rinse: 1/3 cup of detergent (Tide), 2/3 cup of tri-sodium phosphate (Soilex), 1 quart sodium hypo chlorite 5% solution (Clorox), 3 quarts water.

## 12.6

Caulking compounds, oil, grease, tars, wax and similar substances can be removed by wiping with a cloth soaked with WD-40 lubricant or Oil-flo 141. Test on an inconspicuous area first. Do not rub excessively or damage to the finish may result. Wipe only contaminated areas and follow with detergent cleaning and thorough rinsing.

## 12.7

To remove oxidation and tough stains, use a household cleaner recommended for use on porcelain skins and bathtubs. This should be followed with a thorough rinsing. Wire brushing or any abrasive material may damage the painted surface and should not be used.

## 12.8

Special cleaning and maintenance procedures are necessary for Granitstone® panels. Please consult a Project Coordinator or Regional Sales Manager for instructions.

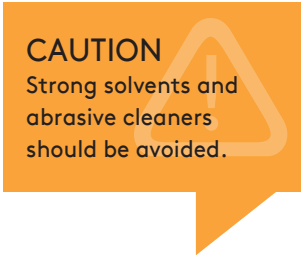

**CAUTION**  
Strong solvents and  
abrasive cleaners  
should be avoided.

## 12.9

Contact Kingspan Customer Service to receive a copy of the complete Kingspan Panel Maintenance Manual.

# Vertical Panel Installation

Inspect panels to be installed on the elevation to be sheeted. Set aside panels with damaged side joints, surface dents or scratches. Remove excess foam (if any) from panel joints to allow proper panel engagement.

**A** Verify that the structural supports are properly aligned **before** installing panels (refer to Section 8 Structural Alignment).

**B** Install base support and associated drip flashings per project details.

## Overhang Condition

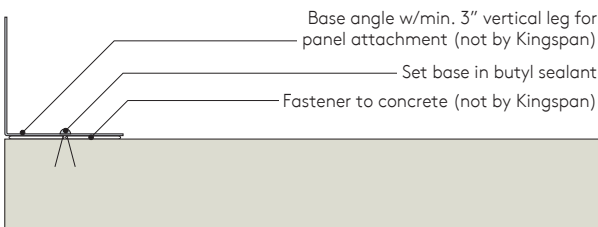

## Flush Condition

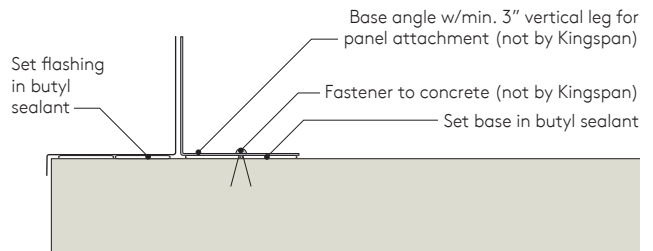

(Typical base conditions)

**C** Install inside corner trim and associated structural supports per project details.

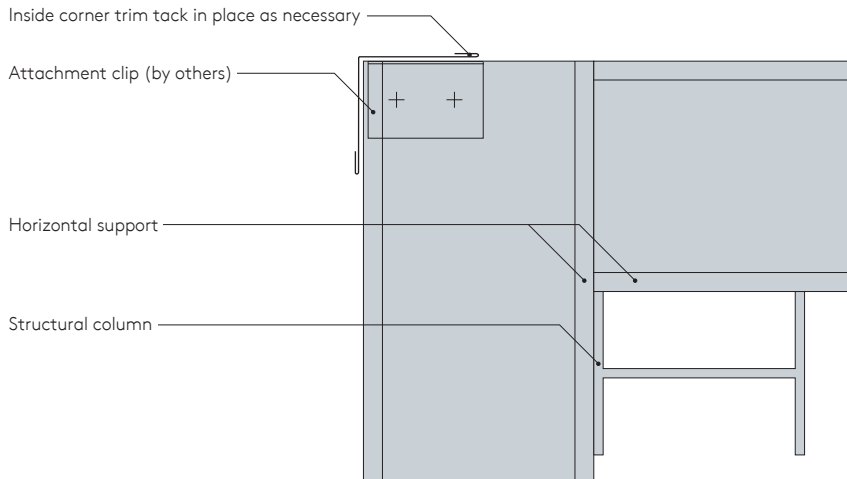

### NOTE

All structural supports are by others (not by Kingspan) and are shown for illustrative purposes only.

# Vertical Panel Installation

**D** Install *interior portion only* of two piece framed opening trims as indicated on project details.  
Tack in place as necessary using pop rivets or similar.

## Two Piece Head Detail

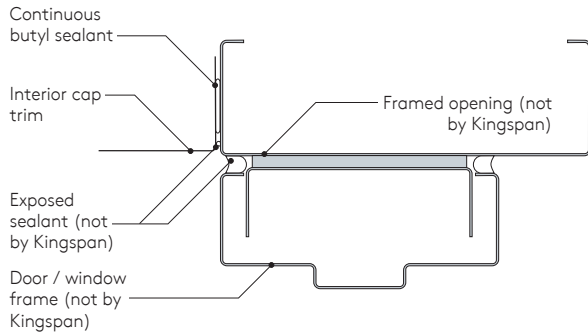

## Two Piece Head Detail with Drip Edge

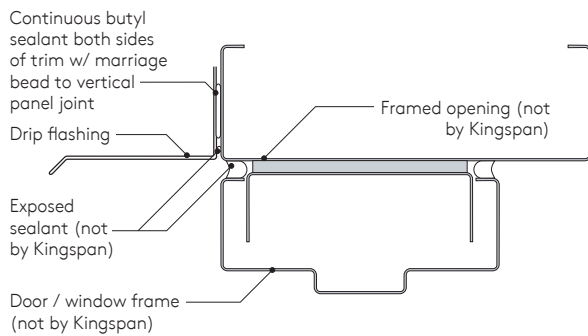

(Typical framed opening head conditions)

## Framed Opening Two Piece Jamb Detail

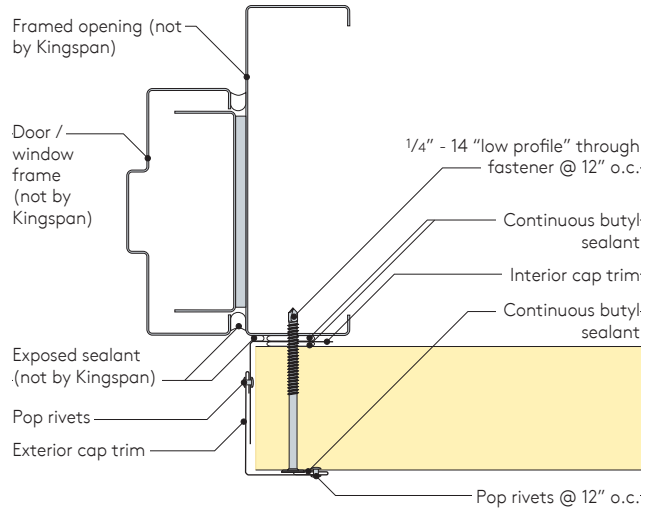

### NOTE

One piece sill trims / extrusions to be installed **AFTER** panel installation, but **BEFORE** exterior header and jamb trims / extrusions are installed.

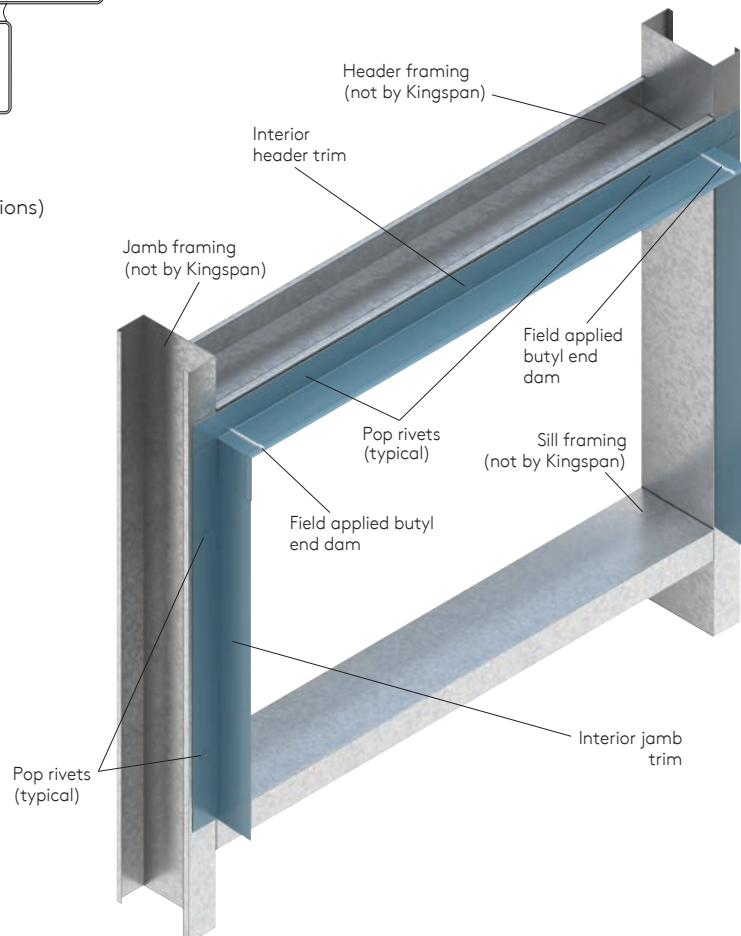

# Vertical Panel Installation

**E** Install butyl sealant (vapor barrier seals) over base support / flashings, inside corner trims, framed openings, eave strut and rake angle per shop drawing details.

## NOTE

It is the installer's responsibility to establish the continuous backside seal using a heavy  $\frac{3}{8}$ " bead of butyl sealants.

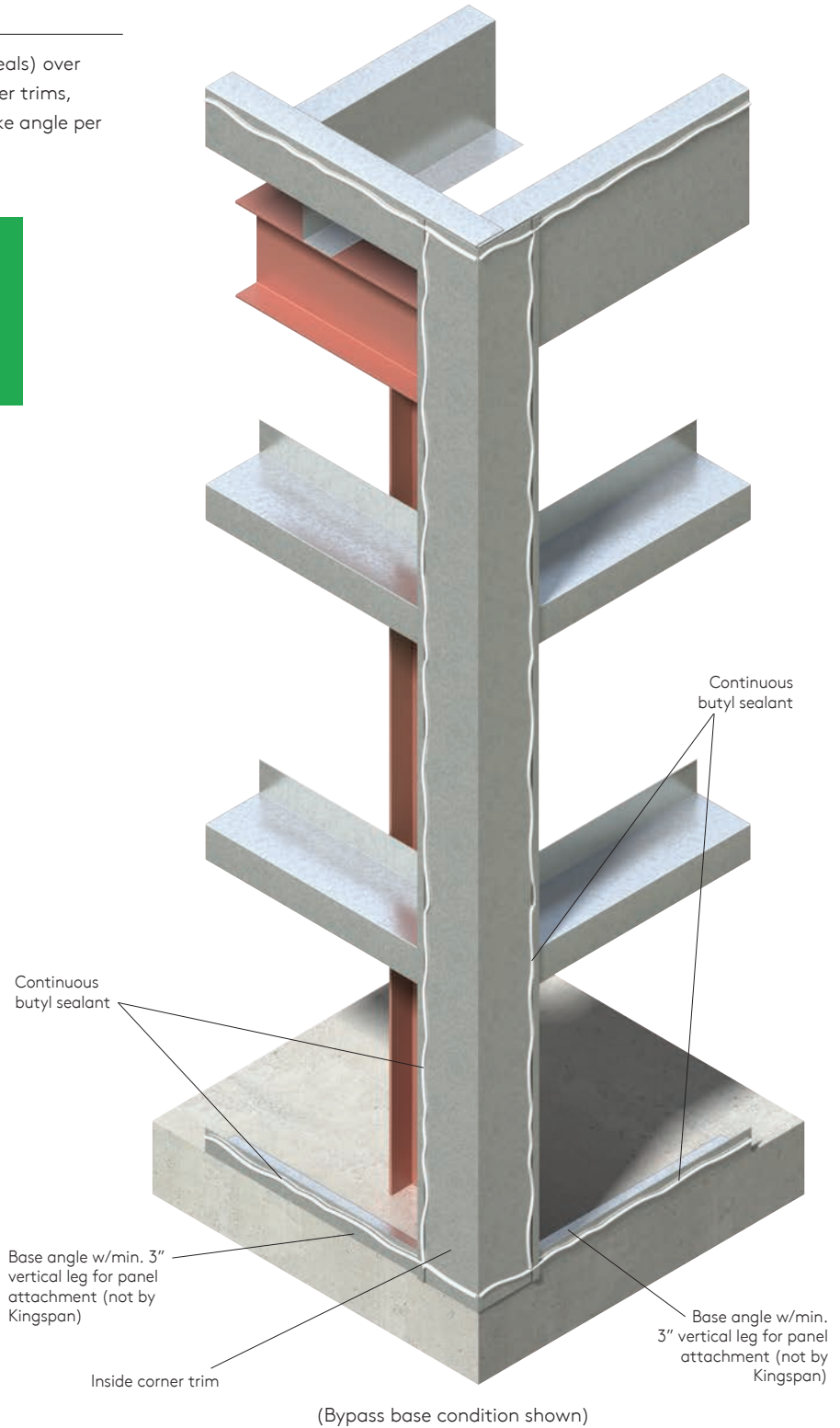

# Vertical Panel Installation

**F** Install butyl sealant on vertical leg of interior framed opening trims to provide proper weather and vapor seals at all framed opening locations.

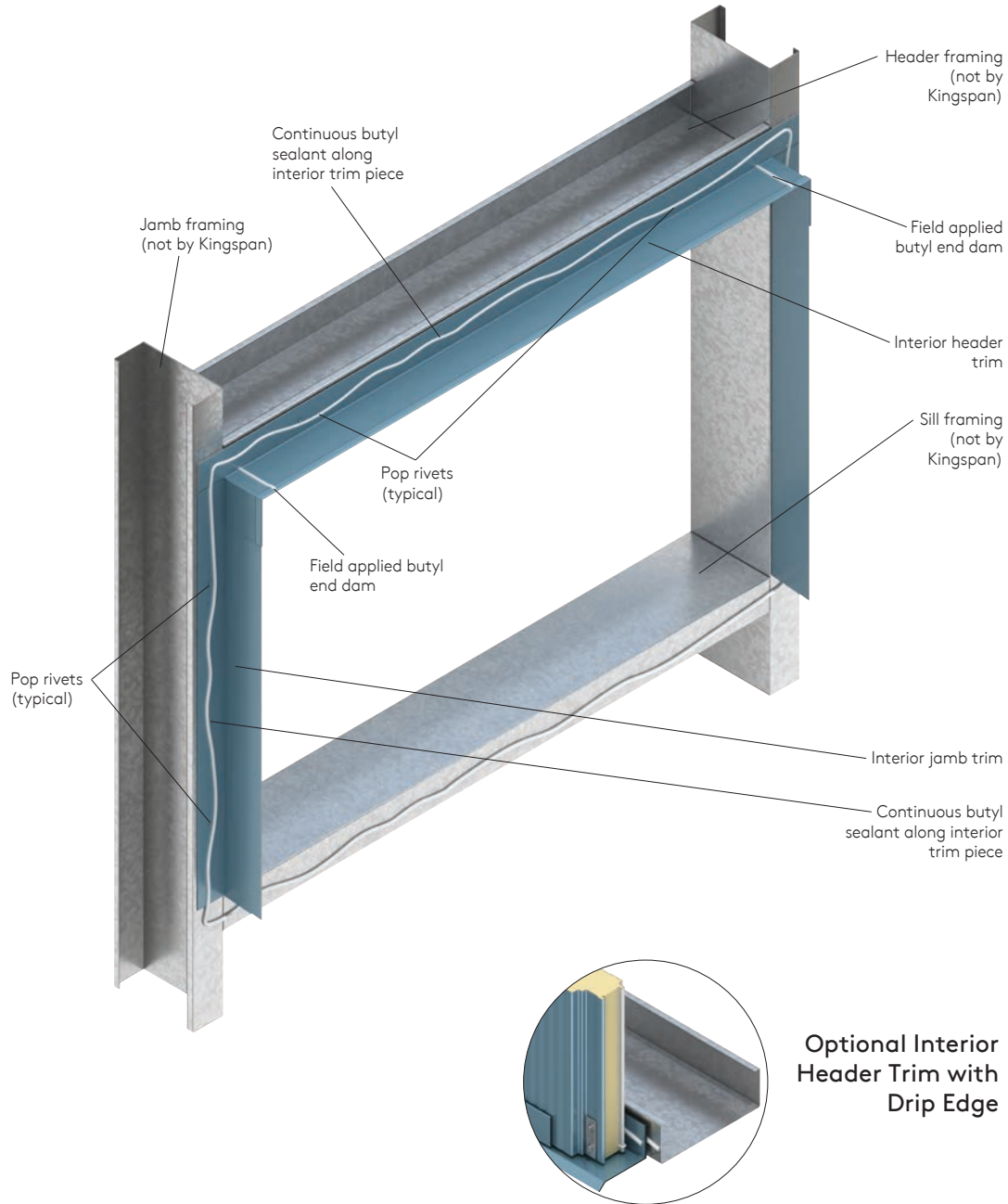

# Vertical Panel Installation

- G** Sheeting is typically installed from left to right. (Sheeting direction may be changed by rotating panels 180 degrees to change direction of joints).
- H** Cut the joints off *trailing* edge of the starter panel as shown. Be sure to cut first panel to proper width so that panel joints at framed openings are properly aligned.

**NOTE**  
Leading edge is defined as the side of the panel that receives hidden clip and fasteners.

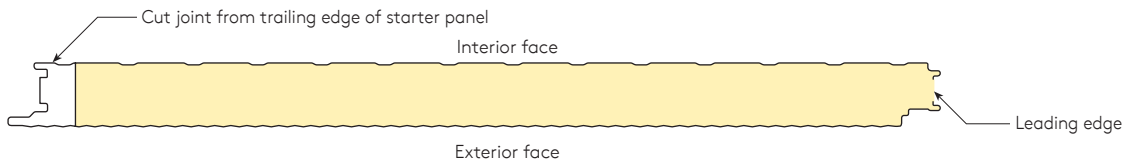

## IMPORTANT INSTALLATION NOTES!

Panel layouts on the shop drawings should be drawn so that the vertical joints of the panel **DO NOT** line up with edges of framed openings. Lining up the vertical joints at penetrations does **NOT** allow proper weather seals due to the offset joint configuration of the KS Series panels.

## Framed Opening Locations

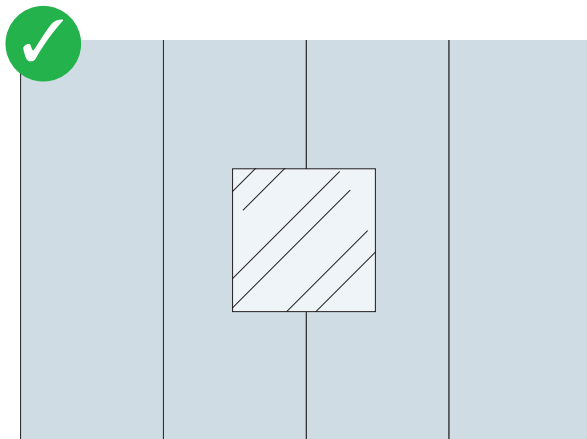

Panel joints offset from jamb  
(preferred condition for better seal at jamb conditions)

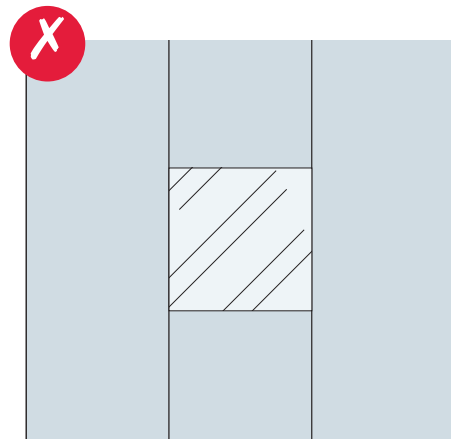

Panel joints align with jamb

# Vertical Panel Installation

- I** Verify liner side joint sealant has been installed (per Section 10). Sealant quantity should be adequate to properly seal male to female joints (approx. 50% to 75% fill in female pocket).
- J** Lift starter panel into place and press firmly into structure to seat panel into butyl sealant placed on the structure and associated trims per step E above.

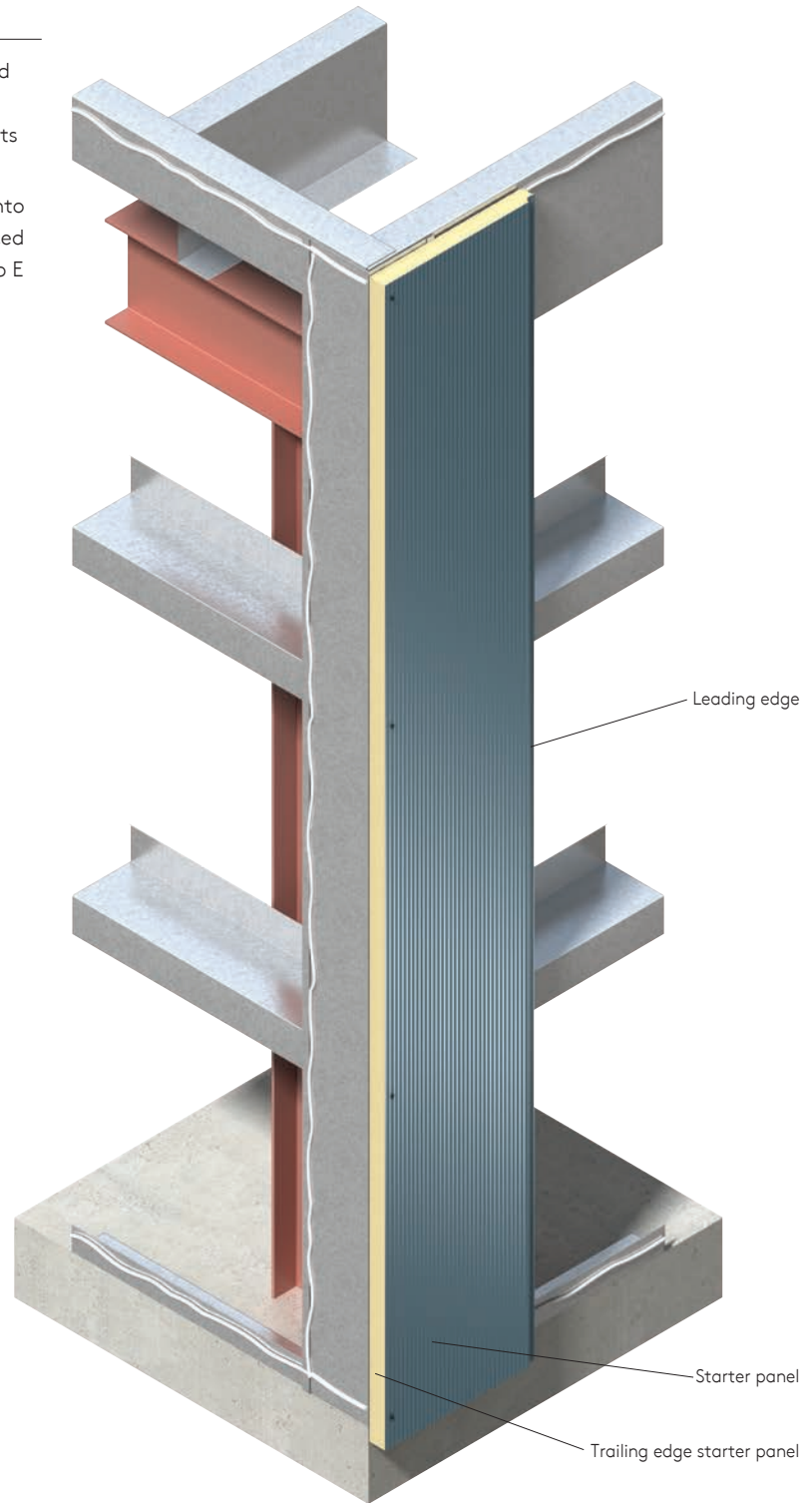

# Vertical Panel Installation

## NOTE

If liner side factory caulking was provided, installer **MUST** inspect sealant bead and modify as necessary to insure a proper panel seal.

- K** Verify panel is vertical using a level placed on leading (non-cut) edge. Install hidden clips with 2 fasteners at EVERY structural support per shop drawings. Also attach trailing (cut edge) of panel to corner structure with fasteners as required per shop drawings. Be careful not to overtighten the fasteners as panel damage will result.

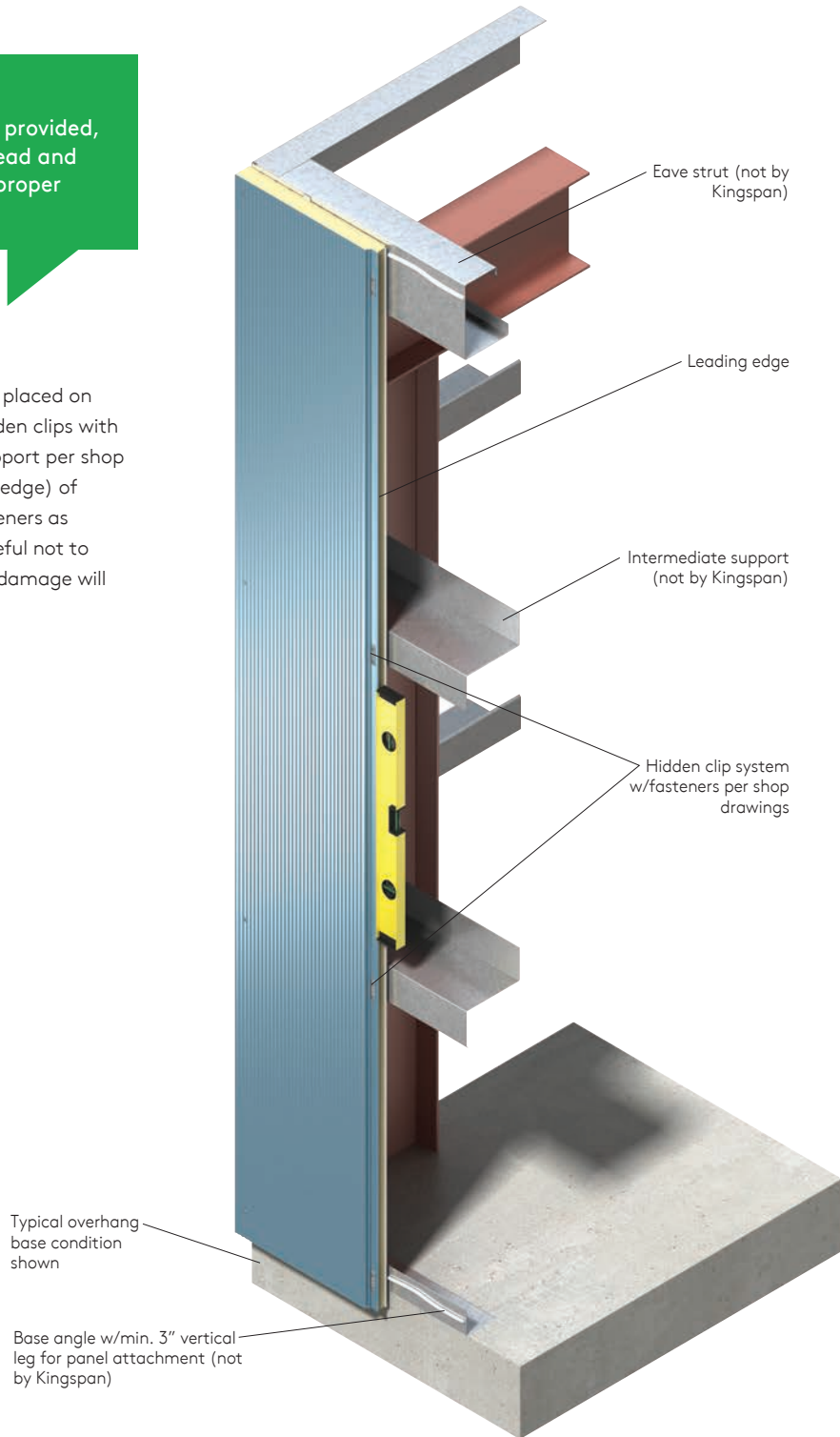



# Vertical Panel Installation

**L** Install marriage bead of sealant from interior joint to supporting structure at EVERY panel termination i.e. - bottom of wall at base support, at framed openings AND at top of wall at eave strut.

**NOTE**  
Marriage beads are critical to ensure proper vapor barriers and are required at all panel terminations.

**NOTE**  
Verify panels are completely engaged, with proper sealant contact and joint reveals.

## Eave Condition

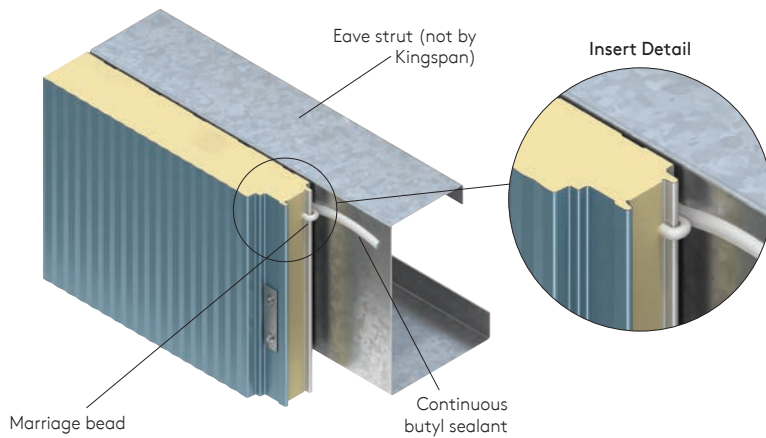

## Framed Opening Condition

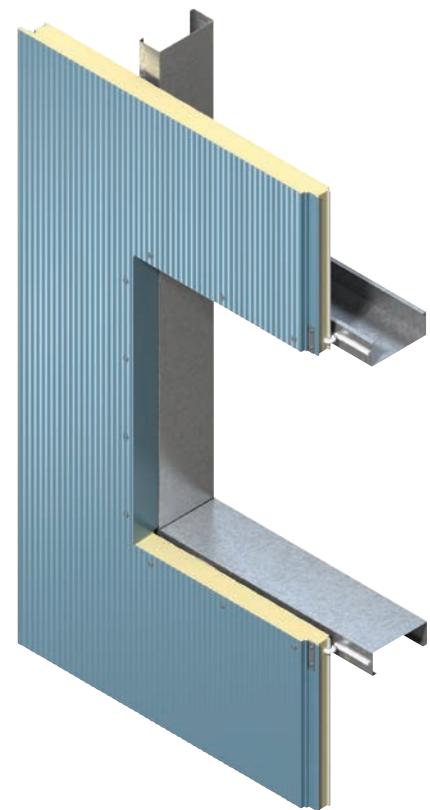

## Base Condition

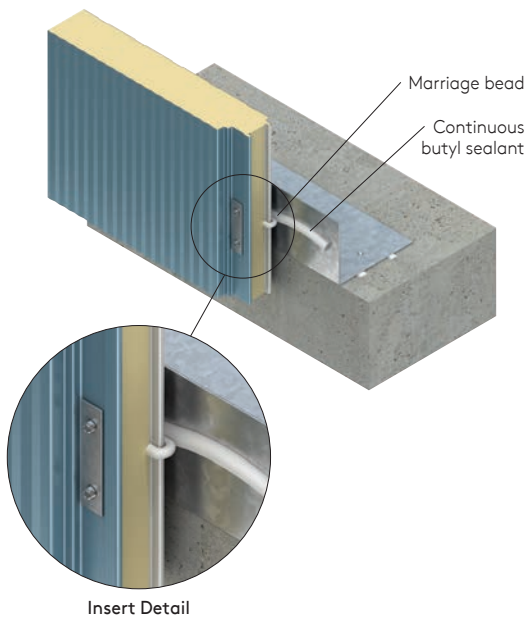

## Framed Opening Head with Drip Edge

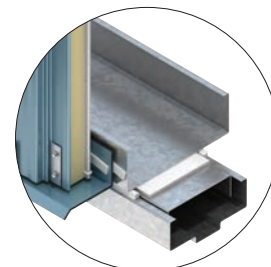

# Vertical Panel Installation

## NOTE

It is generally easier to cut framed openings from panels prior to installing (refer to Section 9 for panel cutting directions). However, extra care must be taken during panel lifting to prevent kinking pre-cut panels. See Section 9.6 for information on cutting panels at framed opening locations.

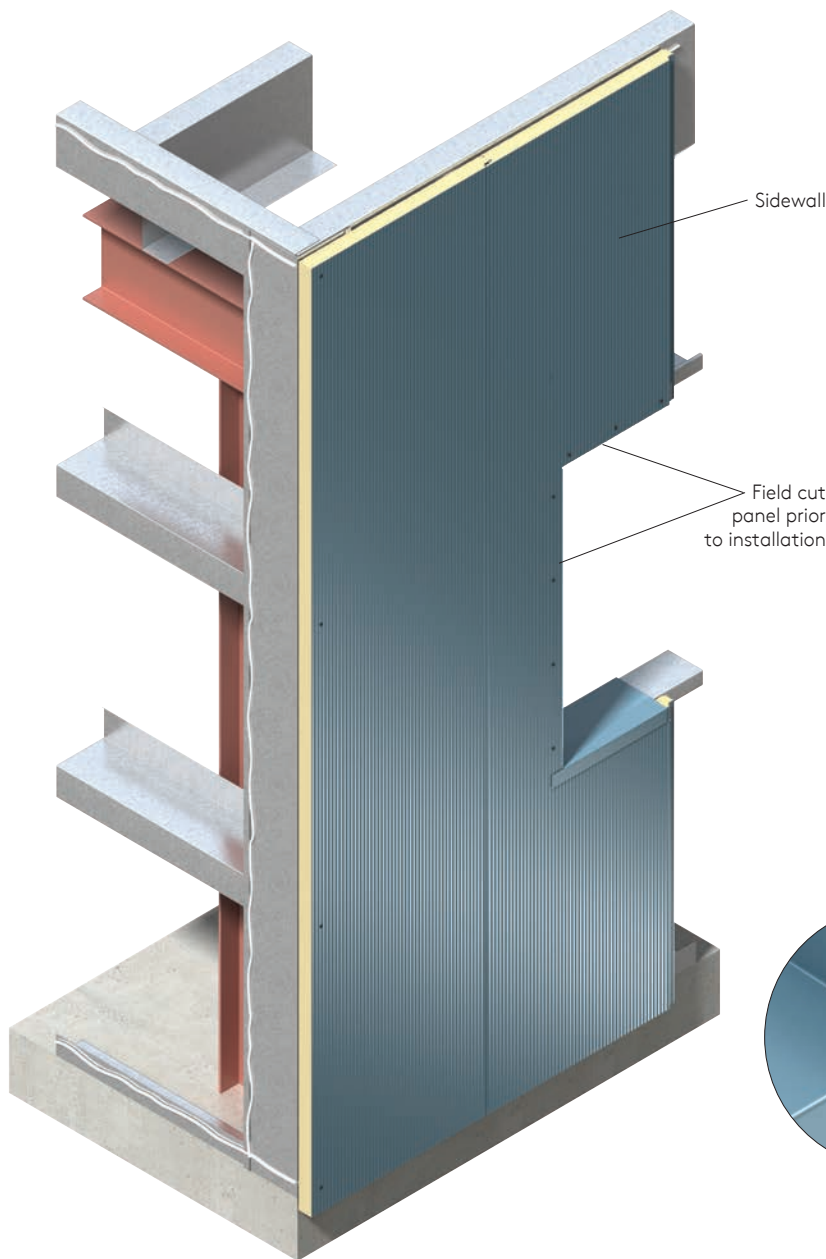

**M** Lift next panel into position and fully engage with previously installed panel. Verify panel is vertical using a level placed on leading edge and install hidden clips and fasteners as required.

Install one piece sill trim / extrusion at framed opening locations as shown.

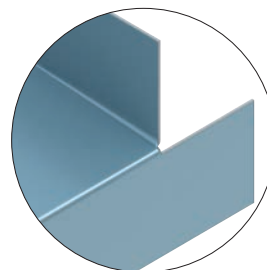

Sill trim with field bent tab

# Vertical Panel Installation

- N** Repeat steps K through M until wall elevation is completed.
- O** Repeat process for other wall elevations. For non-parapet wall conditions, endwall (rake wall) panels must be field cut to match slope of roof.
- P** Once all walls are sheeted, install exterior corner trims, exterior base trims and exterior framed opening trims as required. Follow fastening information on project shop drawings.

## Outside Corner with Flat Trim Detail

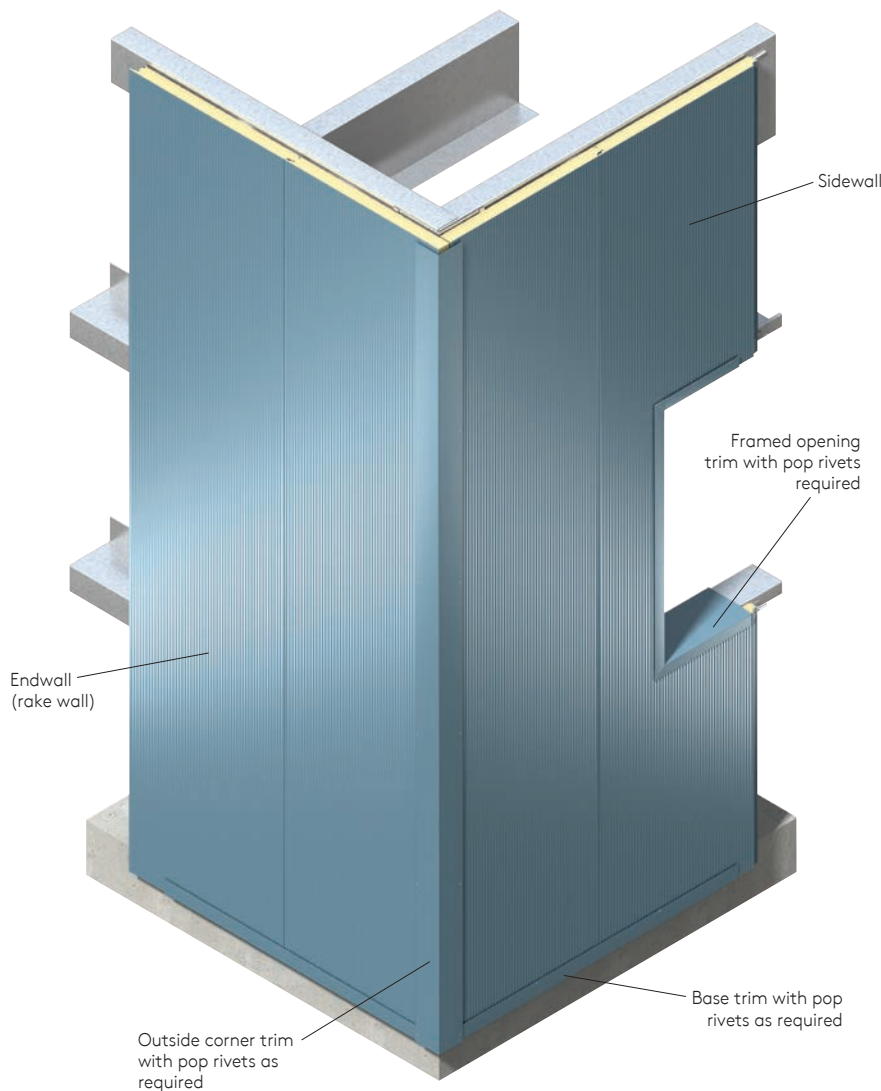
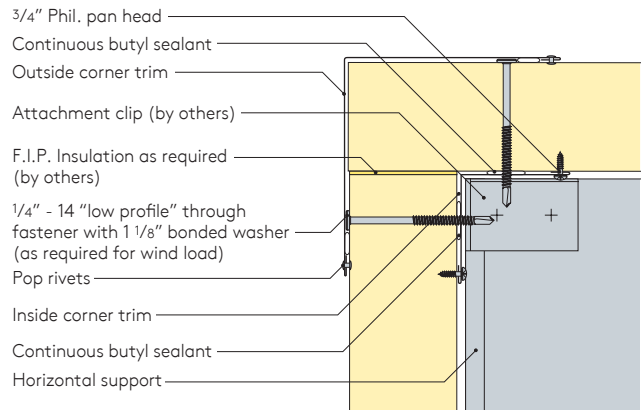

**NOTE**  
 Refer to page 44 for detailed instructions on framed opening trim assembly.

# Fastener Information

This chart is based on data from fastener manufacturers laboratory test results. Since actual job site conditions will vary, chart is a basic guideline. If in doubt, field drilling and pull tests are recommended.

If #14 type 'B' plated fasteners are to be used, pre-drilling is required. Use the drill bit sizes listed below.

## Suggested Fastener Driving Speeds

Quarter inch diameter self drilling, self tapping TEK type and B point self tapping type

Carbon and 410 stainless	1,800 rpm
304 Stainless	1,000 rpm

Note: Proper tools are required to produce consistent drilling and minimize potential fastener or application failures due to over or under driven fasteners. A torque control or depth sensing nose piece for the screw gun is recommended for proper installation.

## Recommended TEK type for 1/4" diameter (self-drilling, self tapping) fasteners

Steel Thickness	TEK	Threads / inch
16 Ga. (0.060)	#2, #3	14
14 Ga. (0.075)	#2, #3	14
12 Ga. (0.105)	#3	14
1/8" (0.125)	#3	14
10 Ga. (0.134)	#3	14
3/16" (0.187)	#3	14
1/4" (0.250)	#3, #5	14 (#3)/20 minimum (#5)
3/8" (0.375)	#5	20 minimum
1/2" (0.500)	#5	20 minimum

## Pilot Hole Chart for 1/4" diameter B Point Fasteners (self tapping)

Steel Thickness	Drill Size
16 Ga. (0.060)	#8 (0.199)
14 Ga. (0.075)	#7 (0.201)
12 Ga. (0.105)	#7 (0.201)
1/8" (0.125)	#2 (0.221)
10 Ga. (0.134)	#2 (0.221)
3/16" (0.187)	#2 (0.221)
1/4" (0.250)	#2 (0.221)
3/8" (0.375)	#2 (0.221)
1/2" (0.500)	#1 (0.228)

To install type 'B' fastener, pre-drill using the correct drill size from chart on previous page. Insert fastener through clip and tighten down until assembly is snug. Panels are to be fastened at every support. Fastener requirements are based on design loads. Consult Kingspan Technical Services for allowable panel and fastener design loads.

Do not use impact tools. Do not over tighten.

After drilling always remove metal chips that have fallen onto flashings or panels.

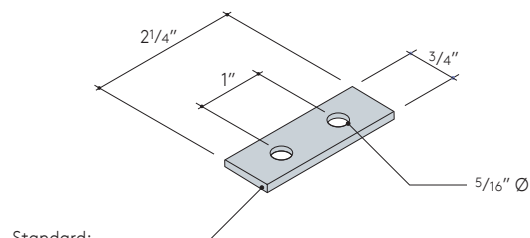
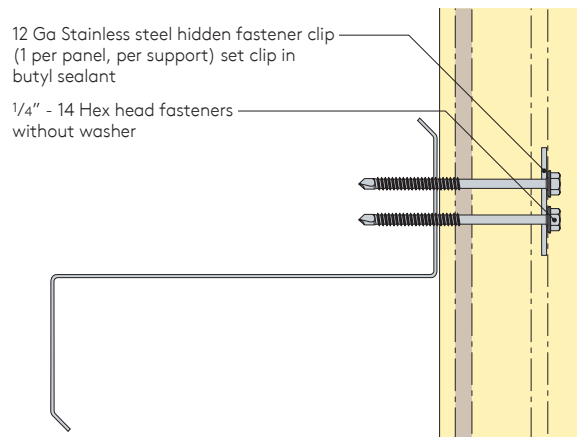

Standard: Stainless steel two-hole hidden fastener clip

### NOTE

Contact Kingspan's Technical Services Department for specific project fastening recommendations.

# Vertical Construction Details

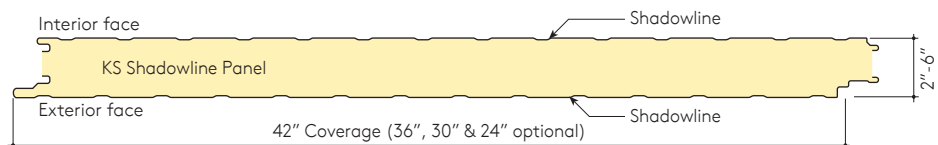
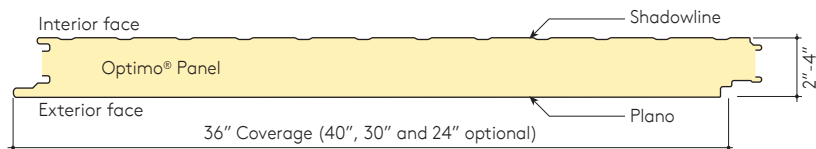
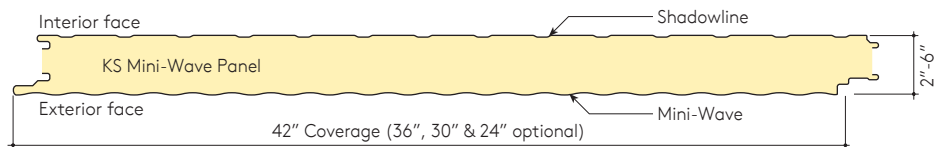
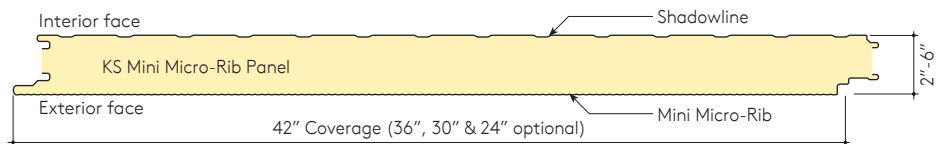
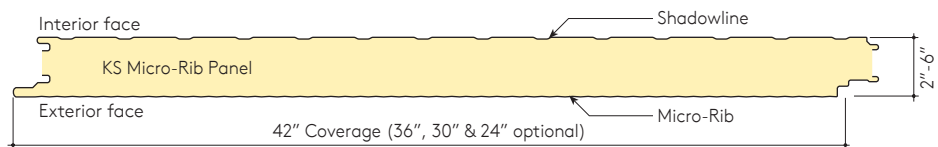
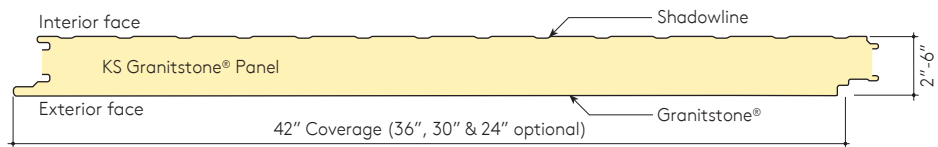
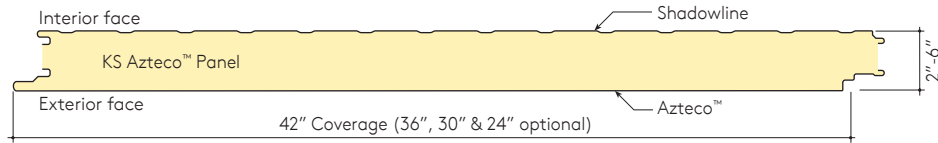

# Vertical Construction Details

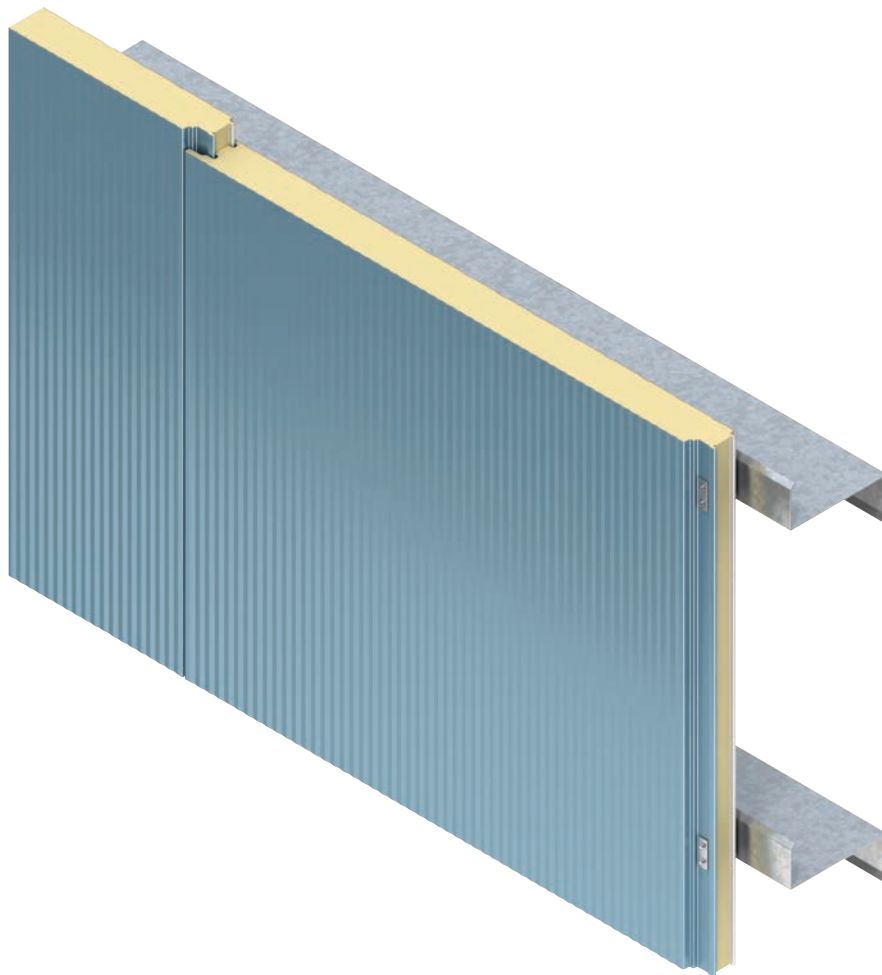
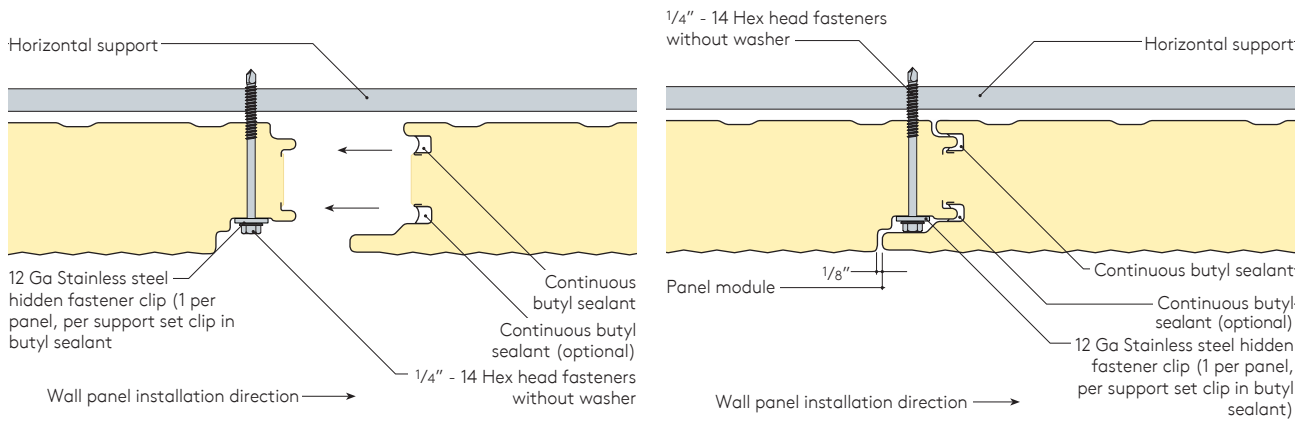

# Vertical Construction Details

**NOTE**  
See details on pages 43 and 44  
for typical trim lap instructions.

## Flush Base Detail

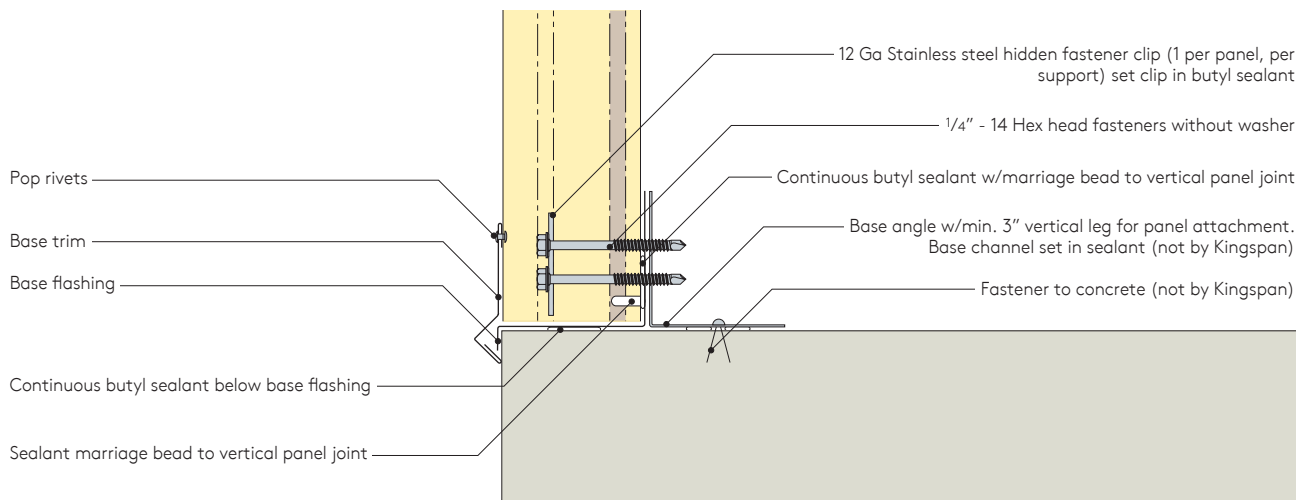

## Base at Notched Concrete Detail

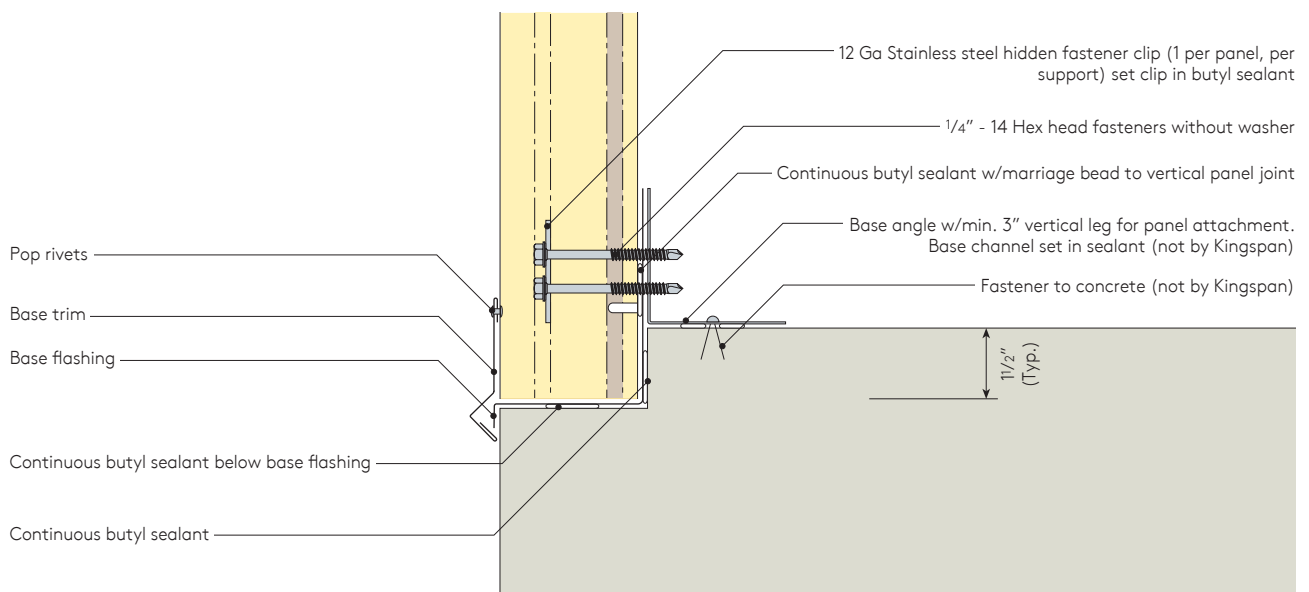

# Vertical Construction Details

## Overhang with Base Support Detail

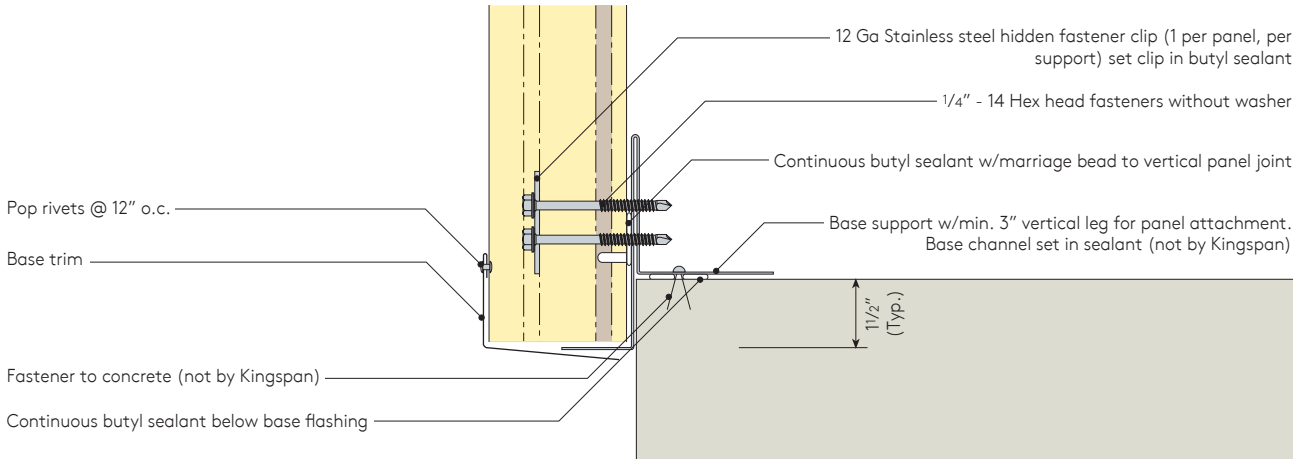

## Overhang with Base Angle Detail

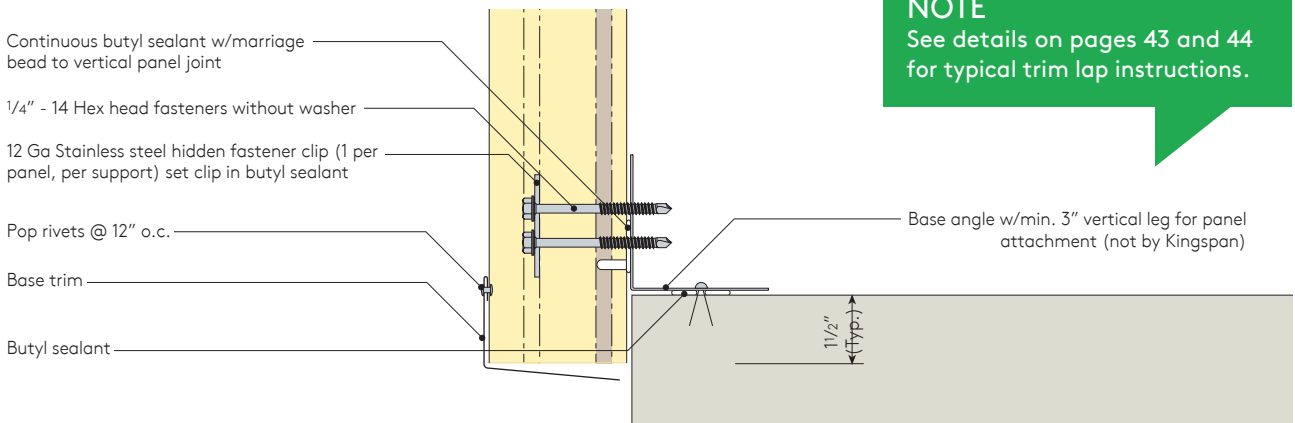

**NOTE**  
See details on pages 43 and 44 for typical trim lap instructions.

## Overhang with Base 'J' Extension Detail

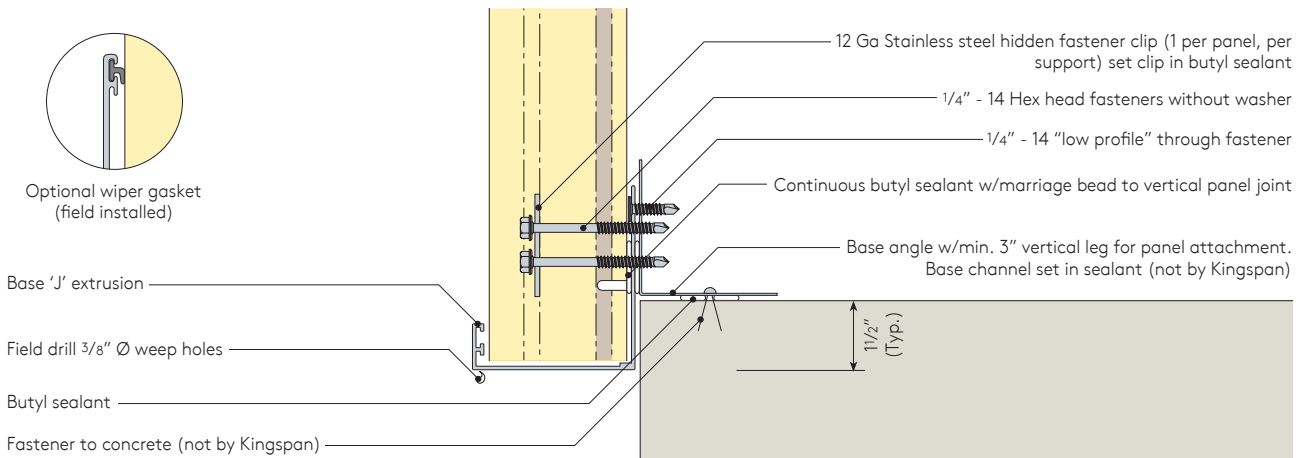



# Vertical Construction Details

## Outside Corner with Profiled Trim Detail

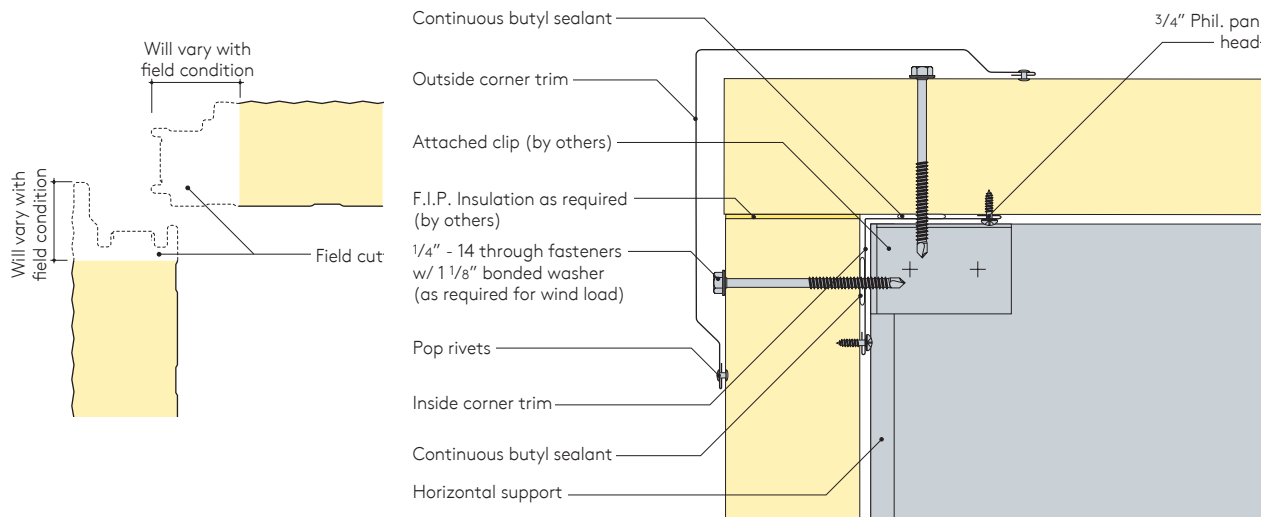

## Outside Corner with Flat Trim Detail

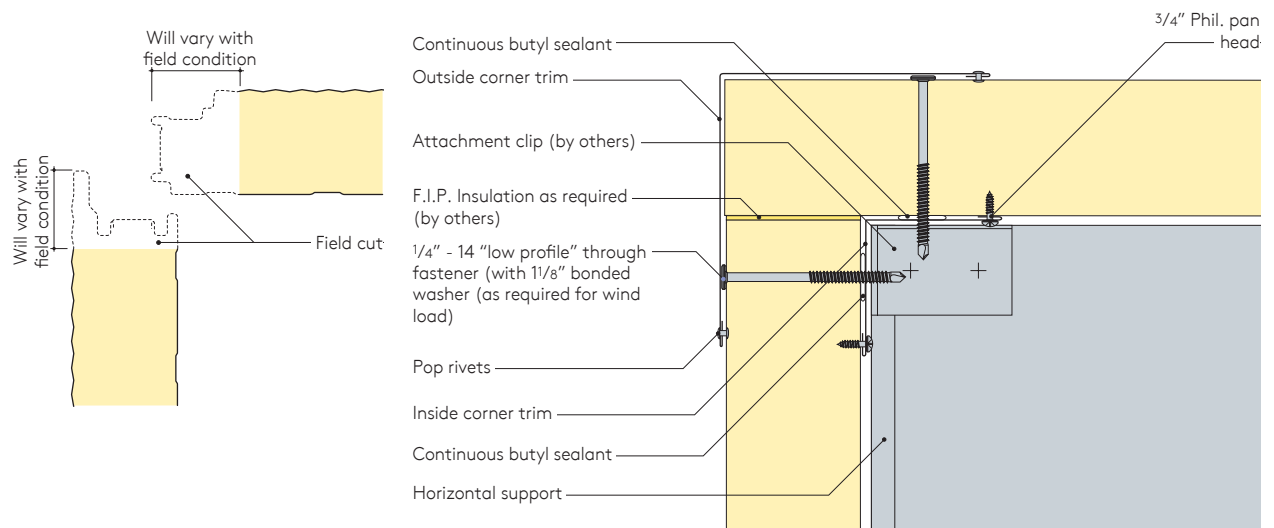

# Vertical Construction Details

## Outside Corner with Extrusion Detail

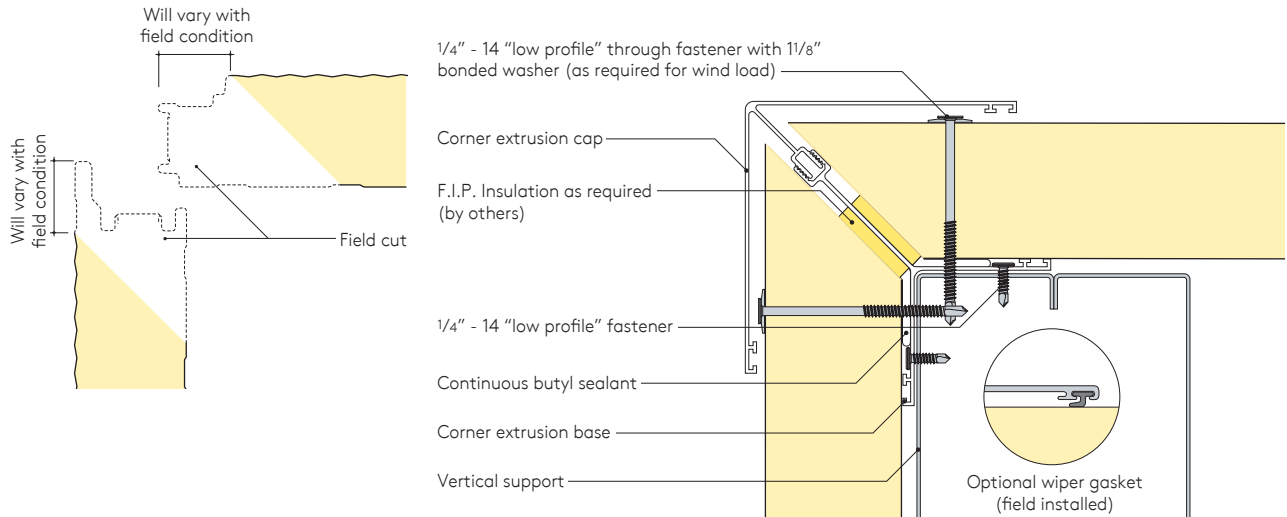

**NOTE**  
Verify wind loads with Kingspan prior to using expansion fasteners for panel attachment.

## Inside Corner with Profiled Trim Detail

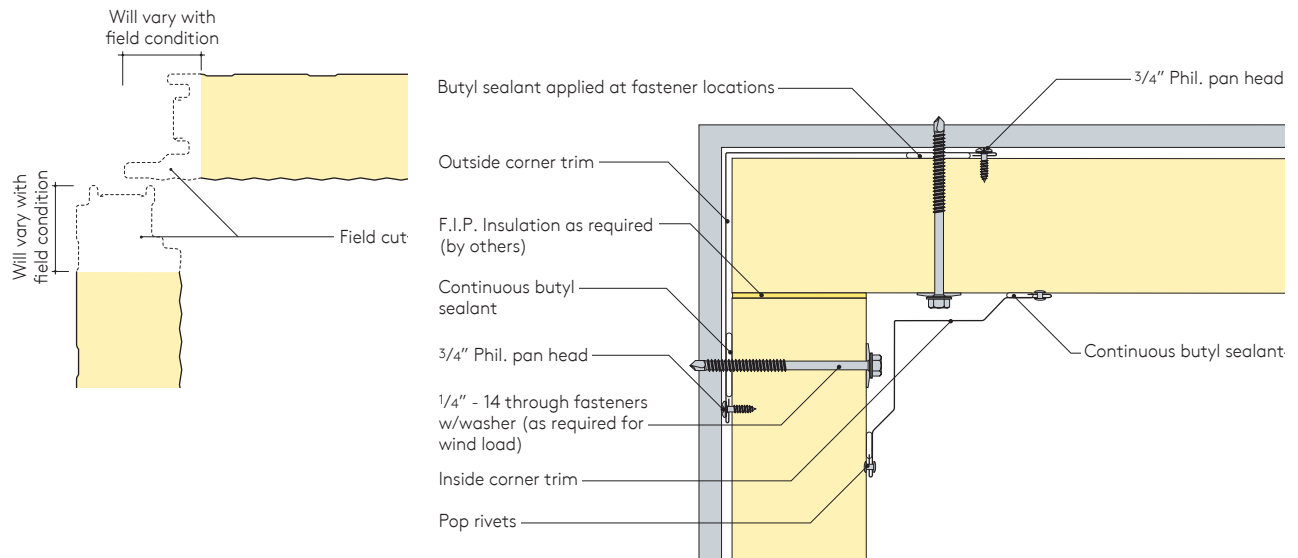

# Vertical Construction Details

## Inside Corner with Flat Trim Detail

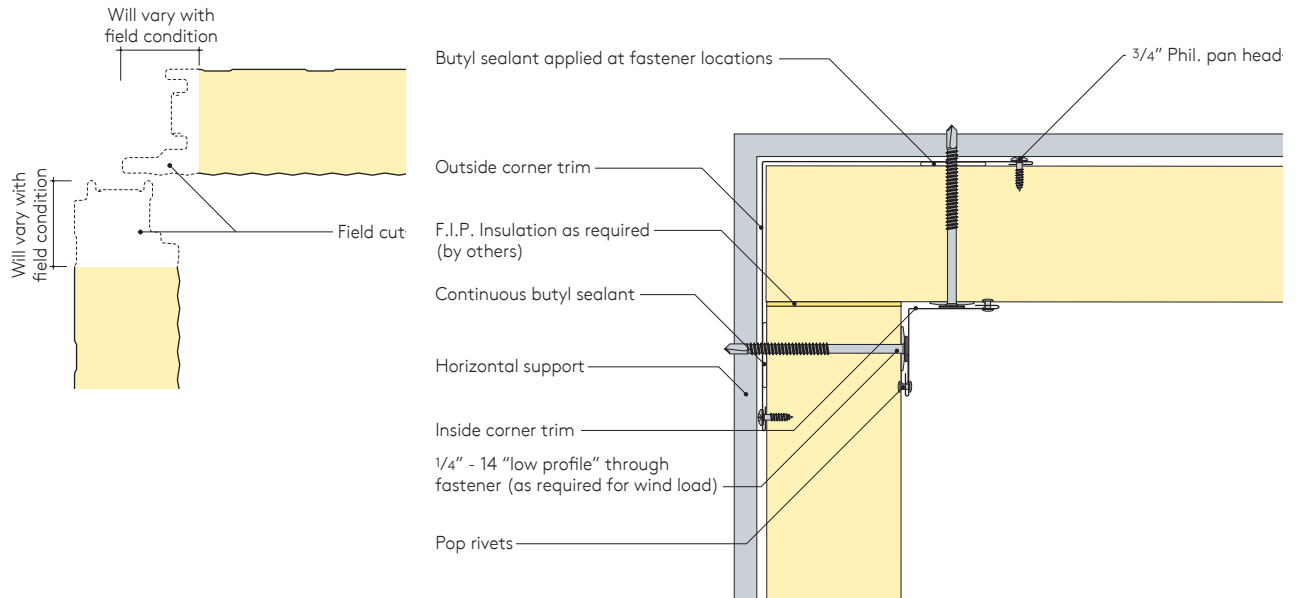

## Inside Corner with Extrusion Detail

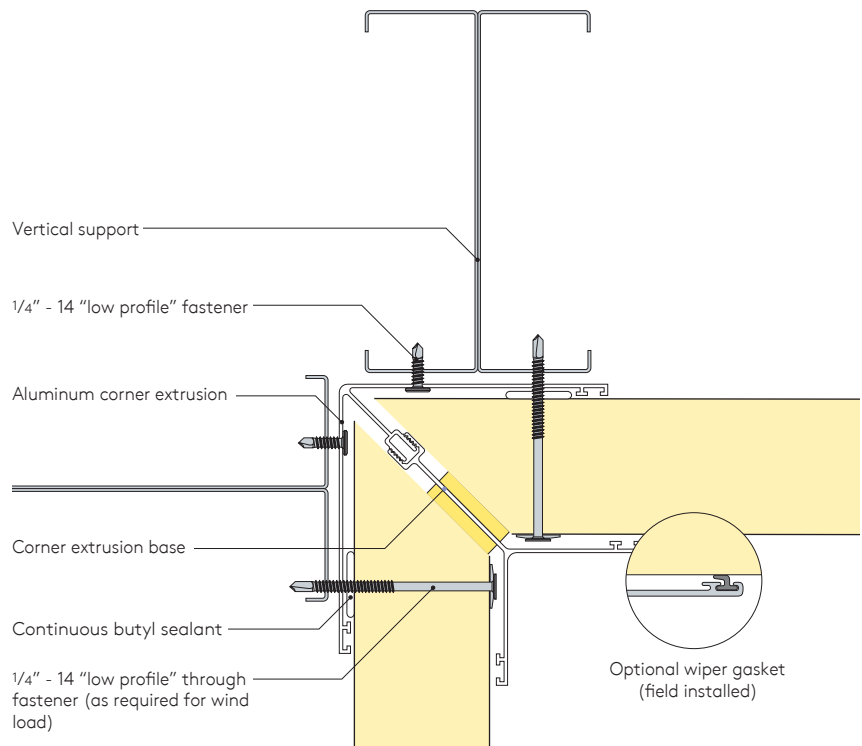

# Vertical Construction Details

## Framed Opening Two-Piece Head Detail

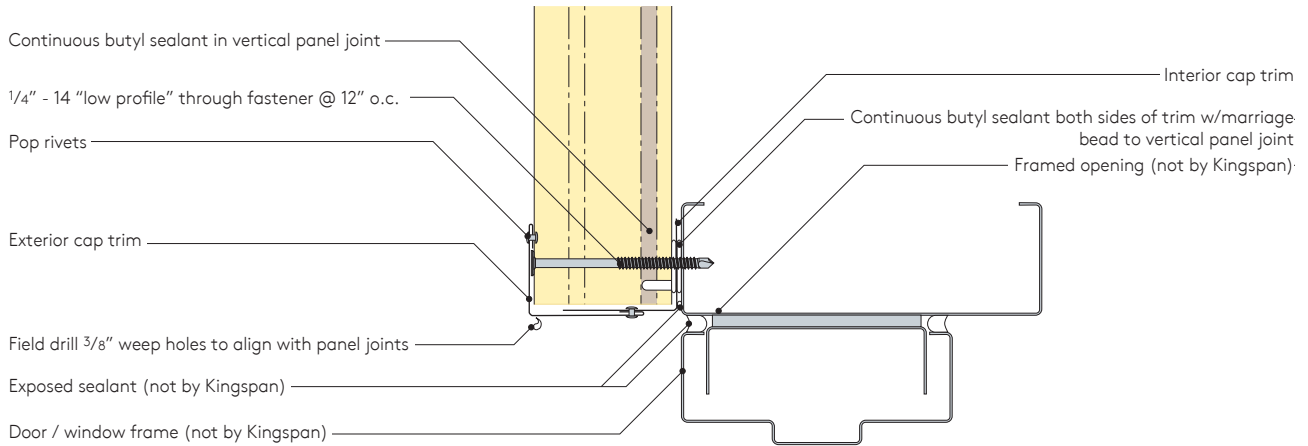

## Framed Opening Head with "Drip Edge" Detail

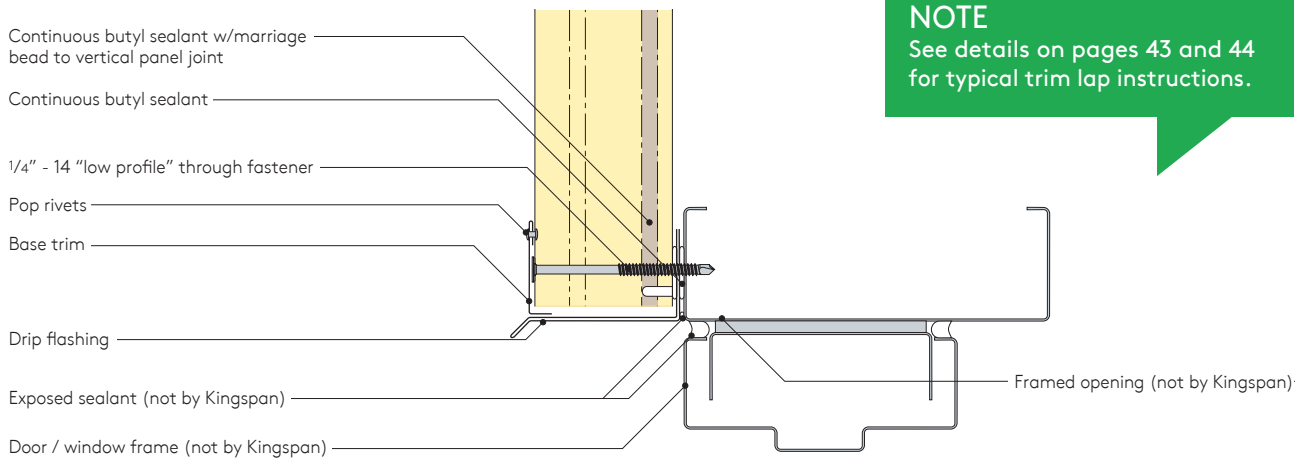

**NOTE**  
See details on pages 43 and 44 for typical trim lap instructions.

## Header with Extrusion Detail

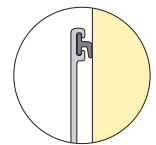
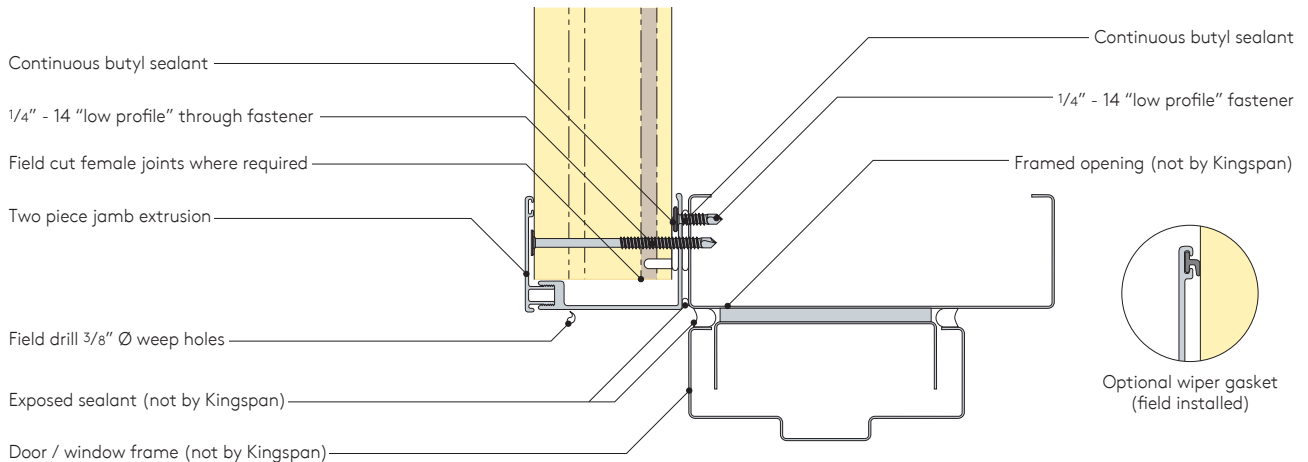

Optional wiper gasket (field installed)

# Vertical Construction Details

## Framed Opening Two Piece Jamb Detail

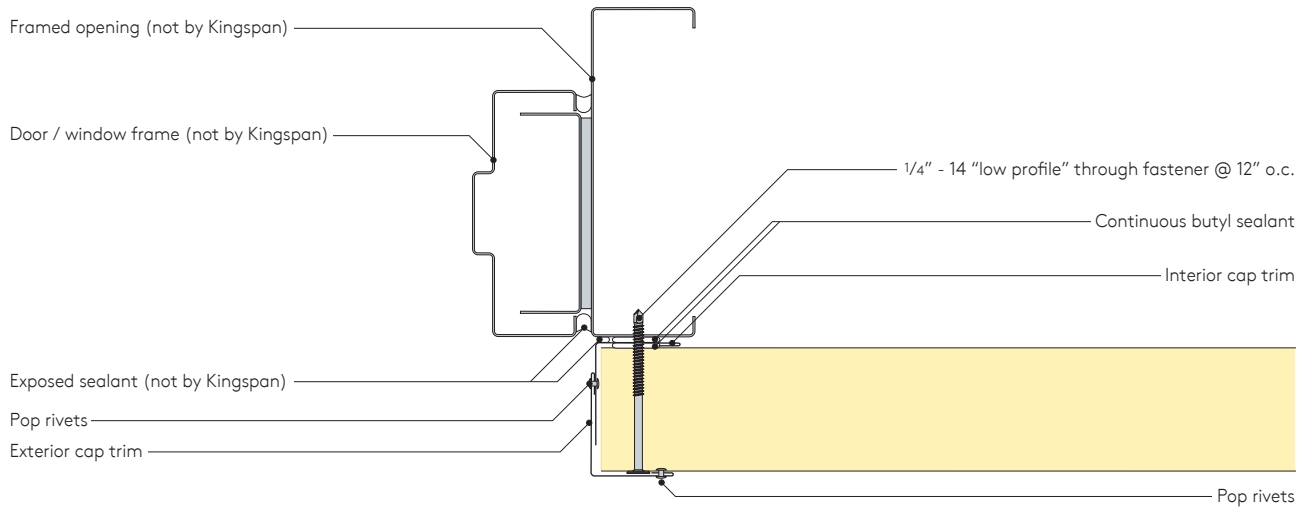

## Framed Opening One Piece Jamb Detail

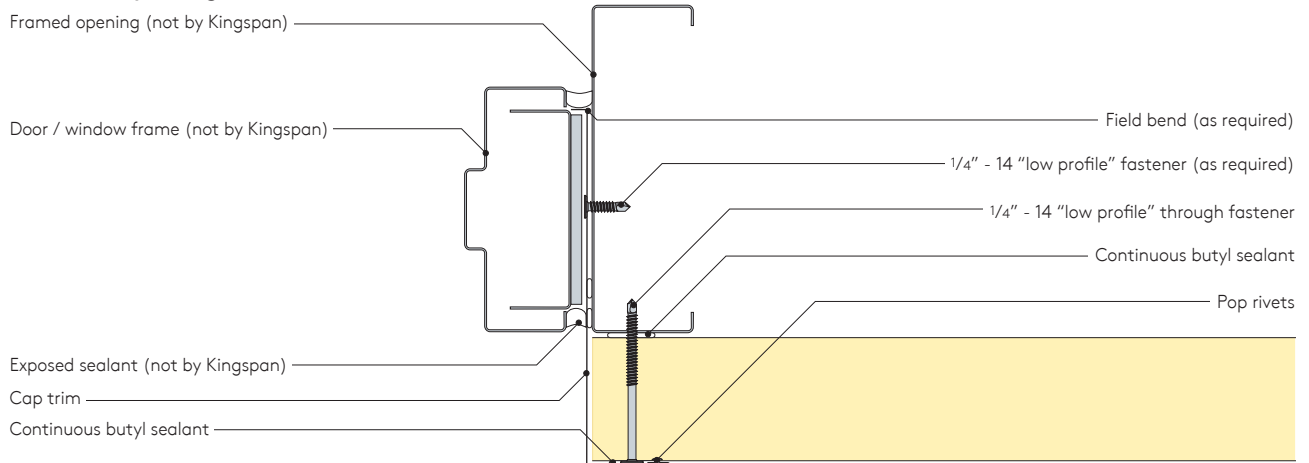

## Jamb with Extrusion Detail

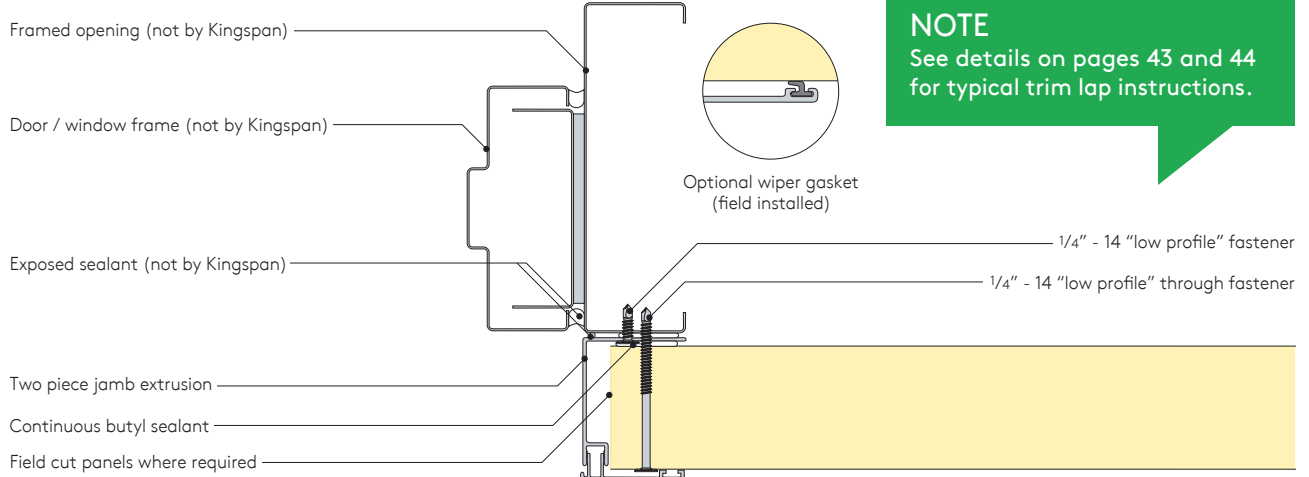

**NOTE**  
See details on pages 43 and 44  
for typical trim lap instructions.

# Vertical Construction Details

## Framed Opening One Piece Sill Detail

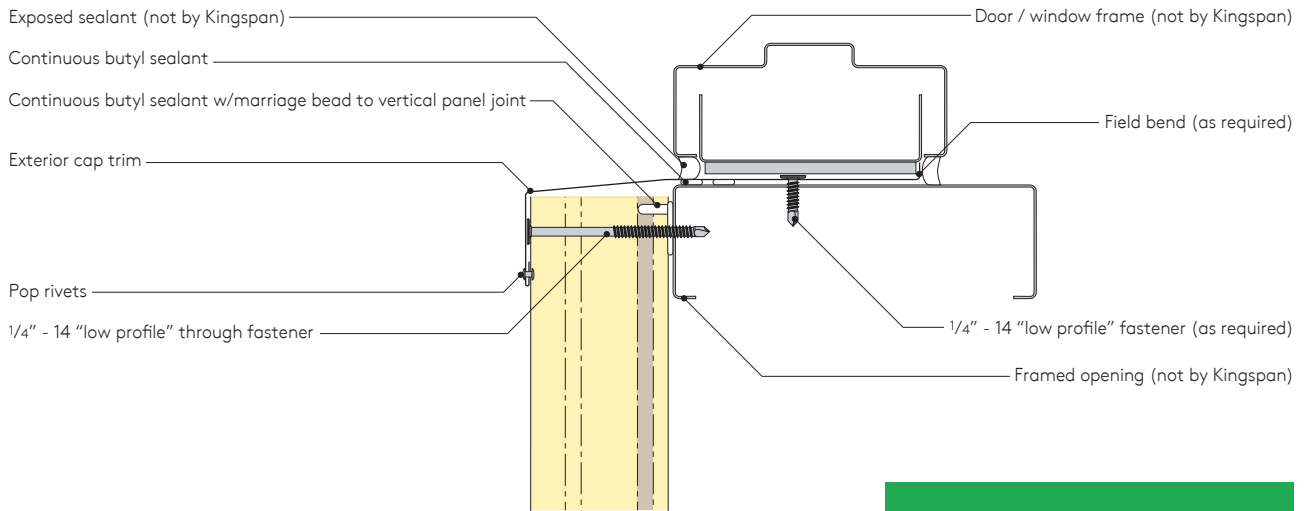

**NOTE**  
See details on pages 43 and 44  
for typical trim lap instructions.

## Sill with Extrusion Detail

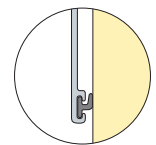
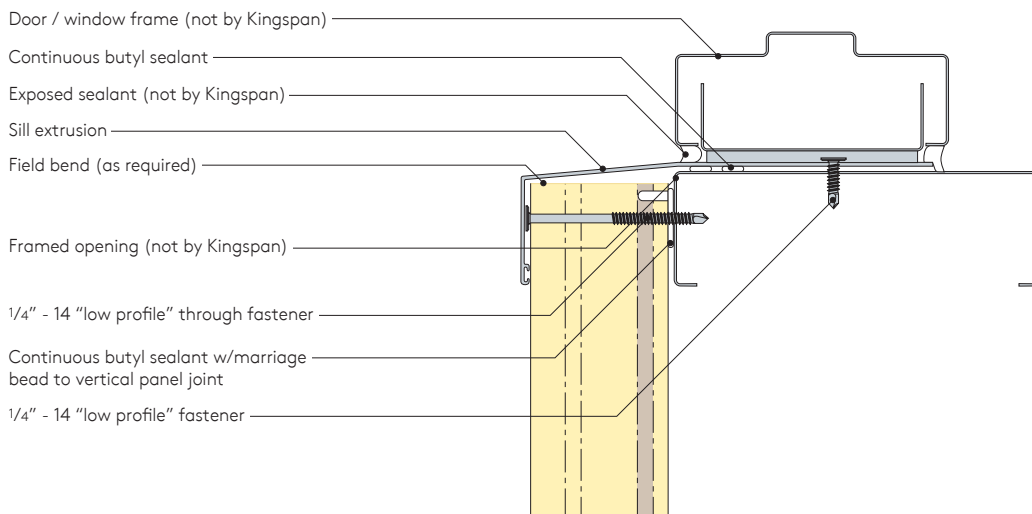

Optional wiper gasket  
(field installed)

# Vertical Construction Details

## Overhead Door Head with Extrusion Detail

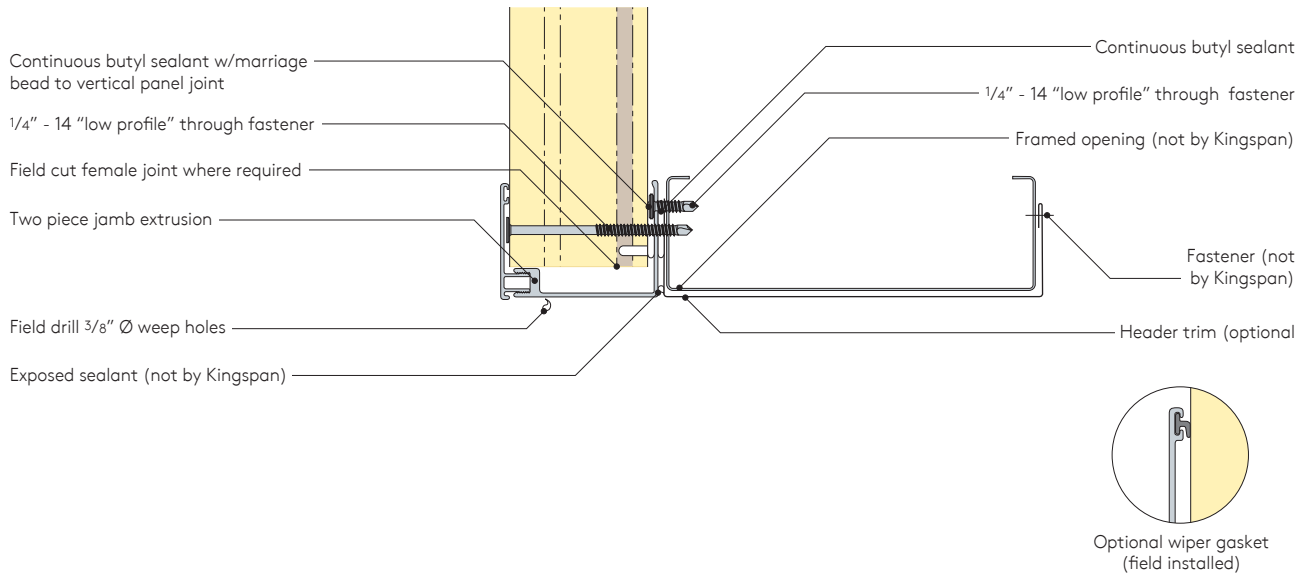

**NOTE**  
See details on pages 43 and 44  
for typical trim lap instructions.

# Vertical Construction Details

## Overhead Door Jamb with Extrusion Detail

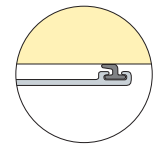
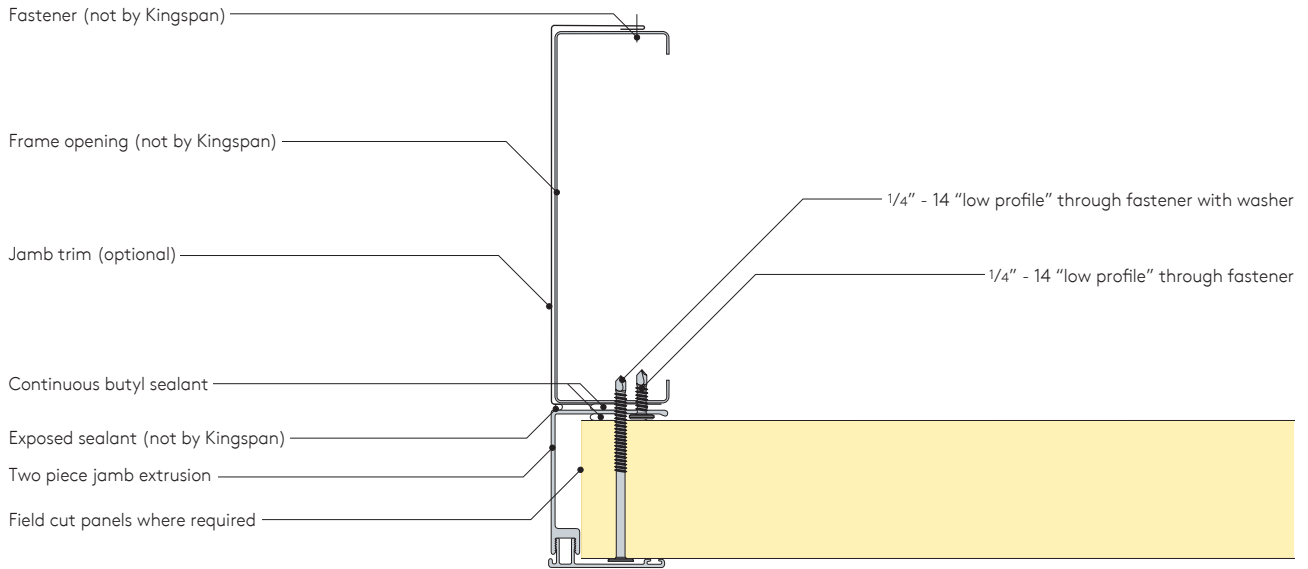

Optional wiper gasket  
(field installed)



# Vertical Construction Details

## Stack Joint Detail

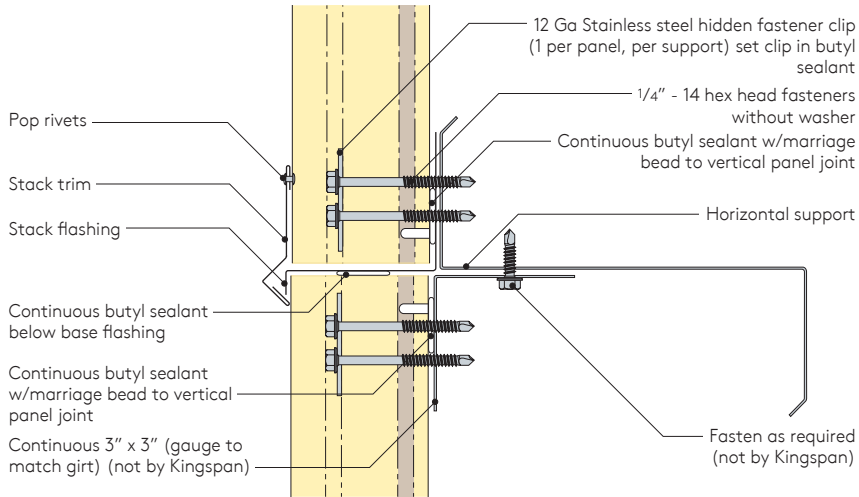

**NOTE**  
For wall elevations requiring stack joints, it is necessary that each column of panels is installed at the same time to maintain proper vertical reveal alignment.

## Stack Joint with Extrusion Detail

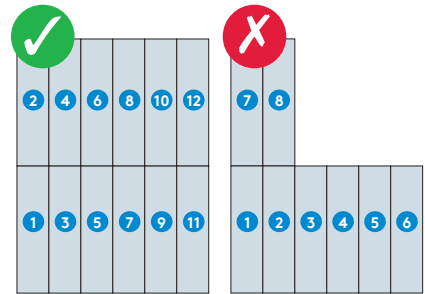
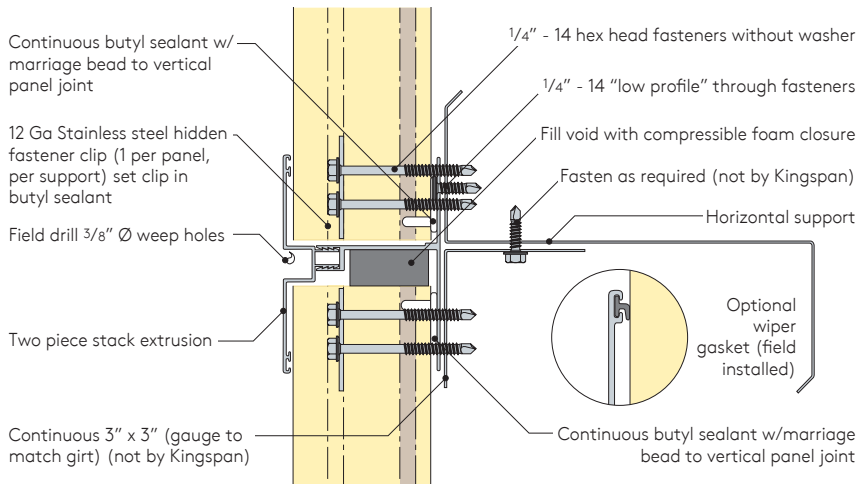

**NOTE**  
Numbers indicate order of panel installation.

## Parapet with Flush Trim Detail

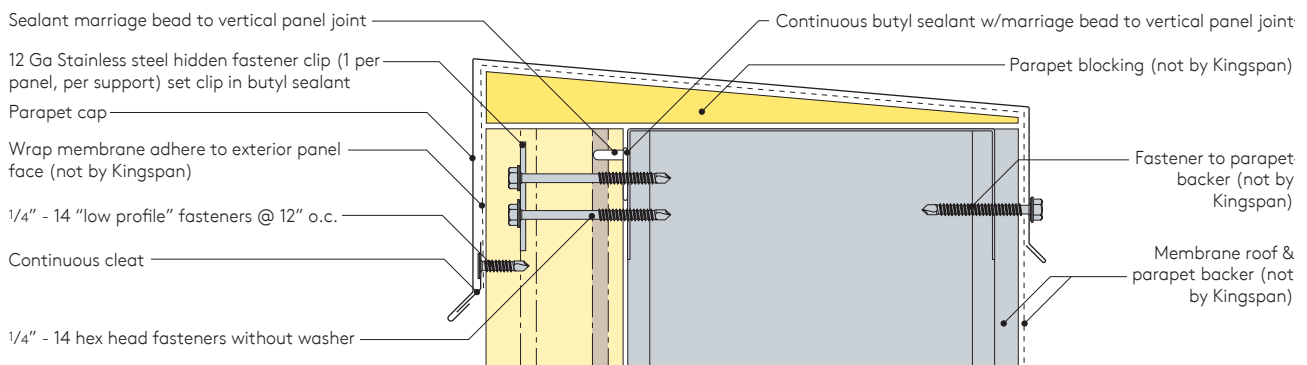

# Vertical Construction Details

## Parapet with Profiled Trim Detail

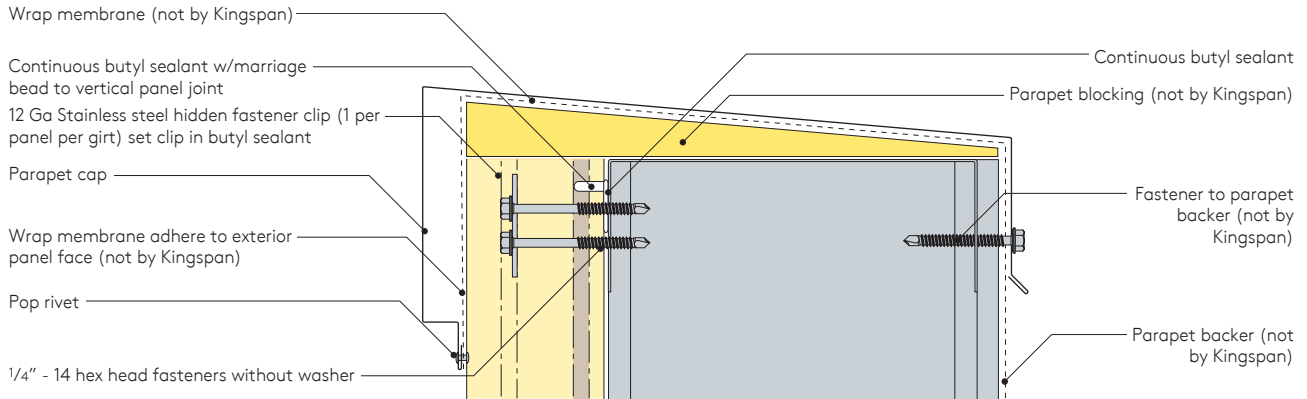

## Parapet with Extrusion Detail

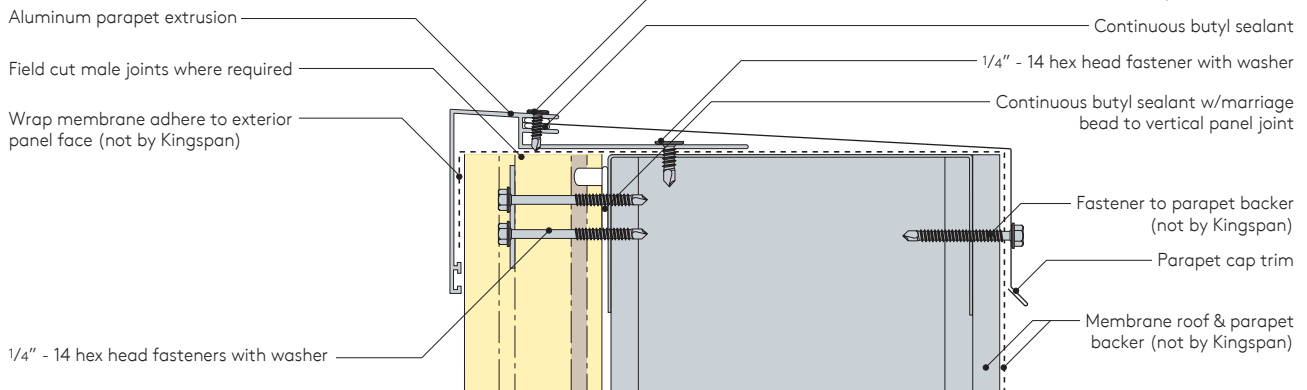

## Framed Opening Partition Details

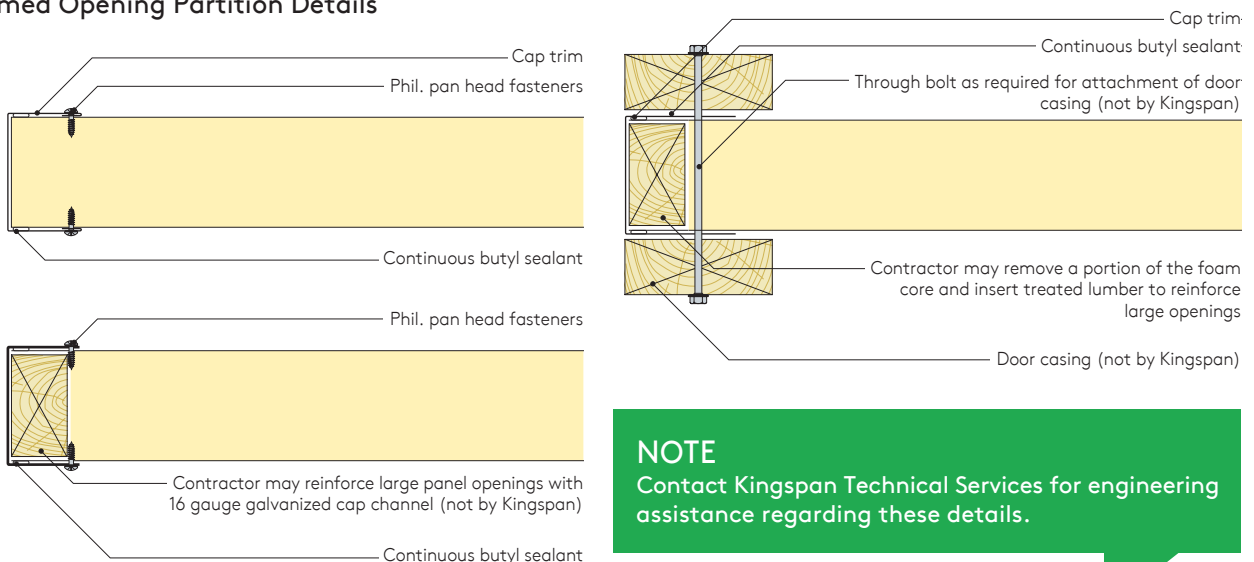

### NOTE

Contact Kingspan Technical Services for engineering assistance regarding these details.

# Vertical Construction Details

Trim End Lap Detail

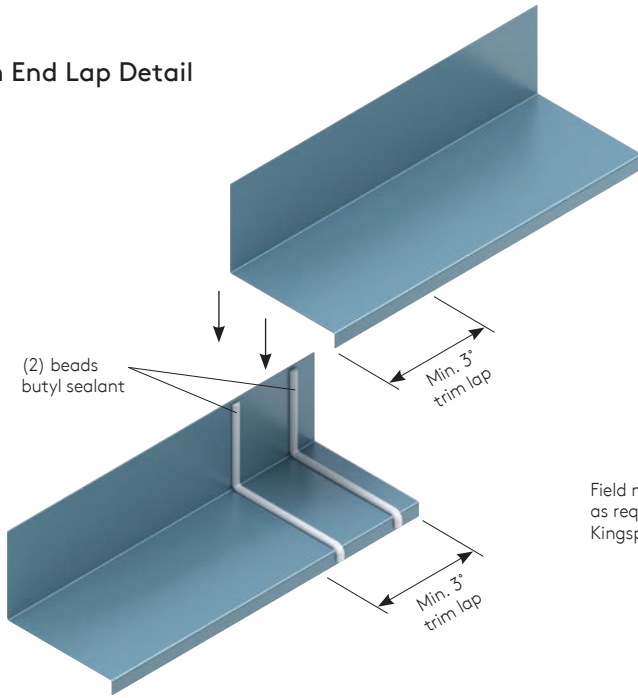

Field notch hem(s)  
as required (not by  
Kingspan)

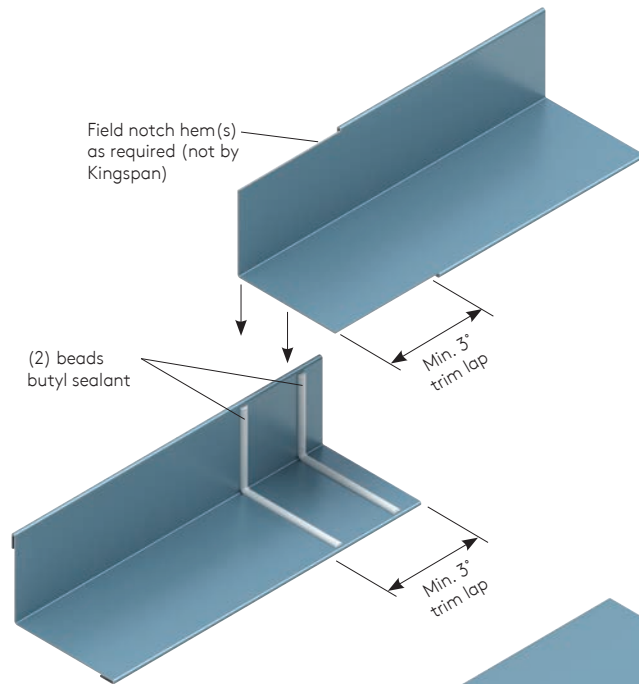

Trim Lap with Hem Detail

Trim End Lap with Lap Strip Detail

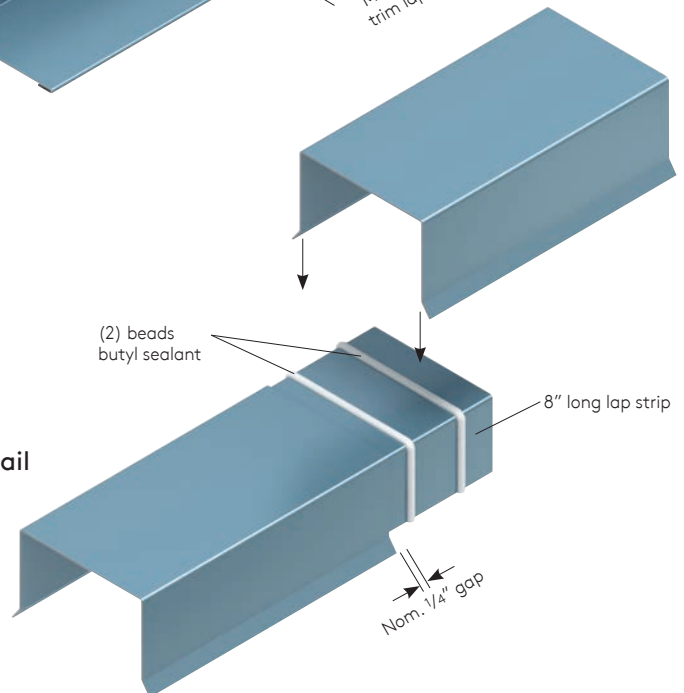

# Vertical Construction Details

## Trim Lap at Framed Opening Detail

**NOTE**  
Weep holes should be aligned with vertical panel joints (not to exceed 24" on center).

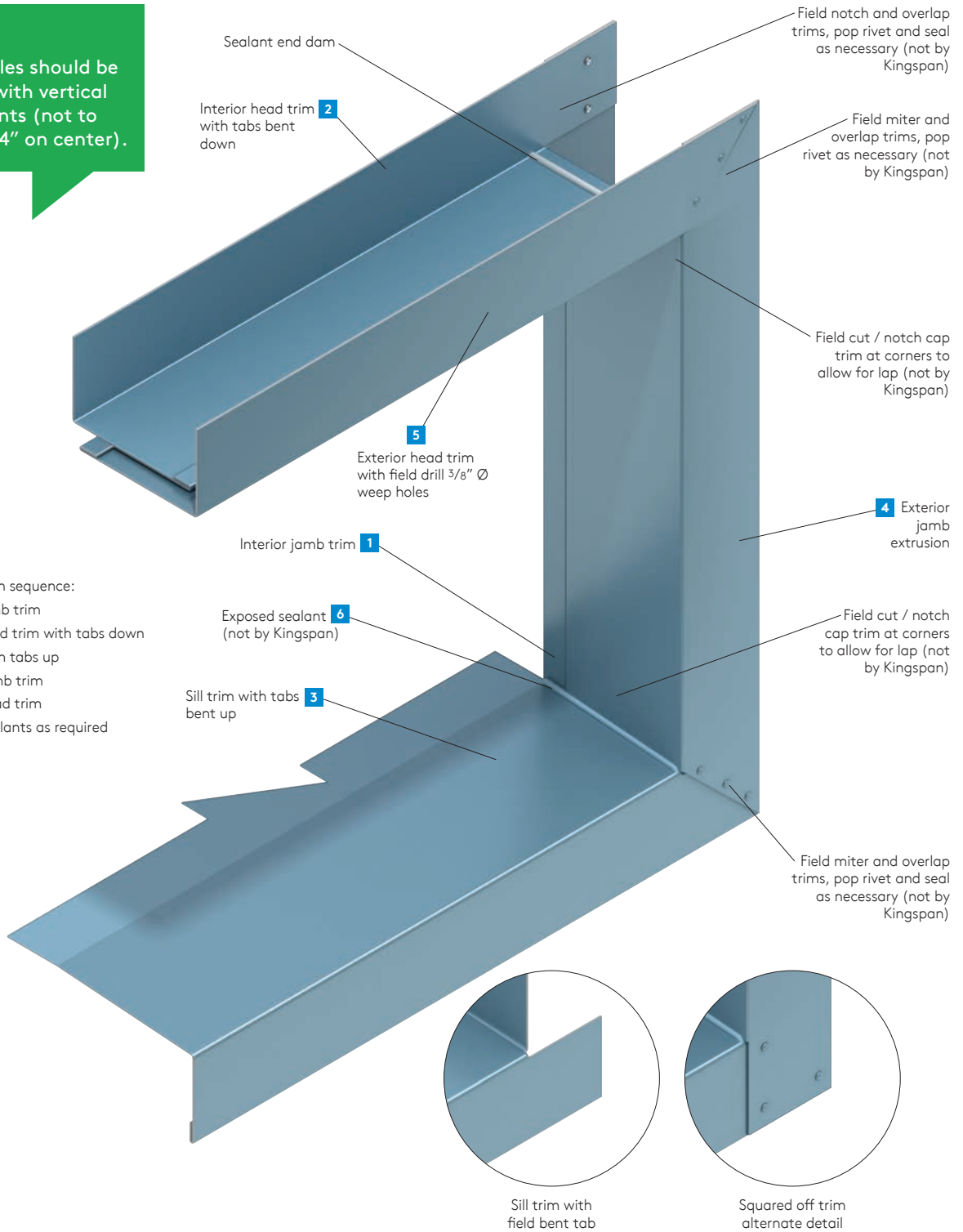

## Vertical Construction Details

### NOTE

Aluminum extrusions may be used in lieu of press broke metal trims. Due to expansion and contraction, it is important to leave a gap of approximately  $\frac{1}{4}$ " at the ends of each piece. Lap strips should be used to keep the extrusions properly aligned and weatherproof. Lap strips for horizontal extrusions should be set in two rows of butyl sealant at each end. Extrusions should be field drilled with weep holes within 2" of the ends of the lap strips to allow adequate drainage.

Lap strip for  
two piece jamb  
extrusion

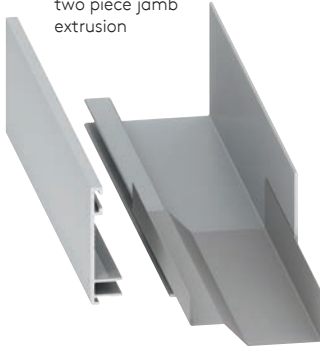

Lap strip for inside  
corner extrusion

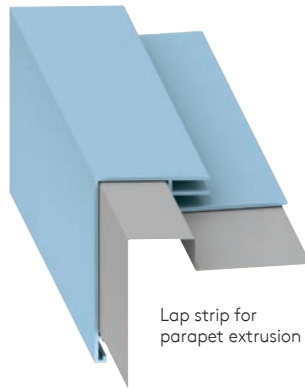

Lap strip for  
parapet extrusion



Lap strip for outside  
corner extrusion



Lap strip for "J" base  
extrusion

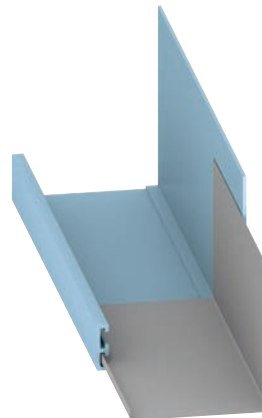

### NOTE

For ease of installation, use a lubricant such as WD-40 or graphite when mating two piece extrusions.

# Vertical Construction Details

## Extrusion at Framed Opening Detail

**NOTE**  
Weep holes should be aligned with vertical panel joints (not to exceed 24" on center).

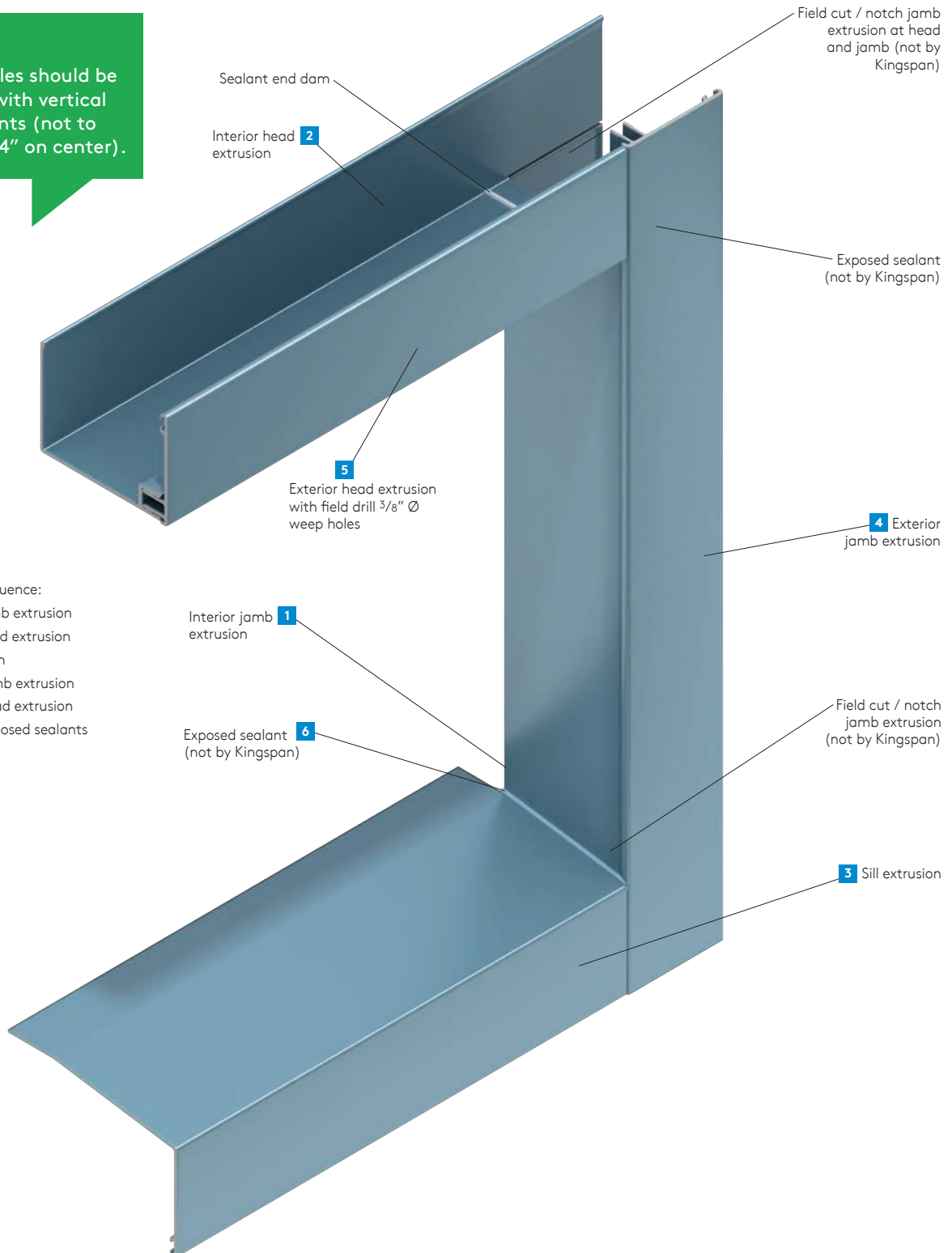

Installation sequence:

- 1 Interior jamb extrusion
- 2 Interior head extrusion
- 3 Sill extrusion
- 4 Exterior jamb extrusion
- 5 Exterior head extrusion
- 6 Exterior exposed sealants as required



# Horizontal Panel Installation

## IMPORTANT INSTALLATION NOTES!

- Minimum width of load-bearing steel exposed behind two horizontal panels at vertical joint is 5" nominal (approx. 127mm) which could be provided by standard double steel stud configuration with steel backer plate. Optional I-beam or HSS steel sections.
- Minimum bearing face for intermediate support is 1.625" (approx. 42mm).
- Where long runs of integrated strip windows are installed, the vertical panel joints should terminate above and continue below the window units.
- Visually check all internal and external tongue-and-groove joints between two adjacent panels to ensure panels are engaged fully and the gaps do not exceed tolerances.
- Details shown in this guide are for reference only. Consult project shop drawings for actual details required.

---

**A** Verify that all structural supports are properly aligned **before** installing panels (refer to Section 8 Structural Alignment - Horizontal Panels).

**B** Install continuous mending plates at all vertical reveal locations. Using a level, mark the centerline of all vertical reveal joints on mending plates to match locations shown on shop drawings.

If the structure does not meet alignment specs, it should be straightened. Shimming is not recommended at the vertical joint, as the mending plate must be fully supported and firmly against the backside of the panel with minimal gap to establish and hold the seal.

**C** Verify all framed opening locations. Apply butyl sealant to outside face of steel supports / studs around framed openings. Install interior portion of two piece trims / extrusions, tack in place as necessary.

Apply butyl sealant to exterior side of interior trims / extrusions around perimeter of opening to form vapor seal to back side of panels (as shown on page 49).

## NOTE

Care must be taken to properly seal all framed openings. Sealant **MUST** be installed between trims / extrusions and supporting steel **AND** between trims / extrusions and back side of panels.



# Horizontal Panel Installation

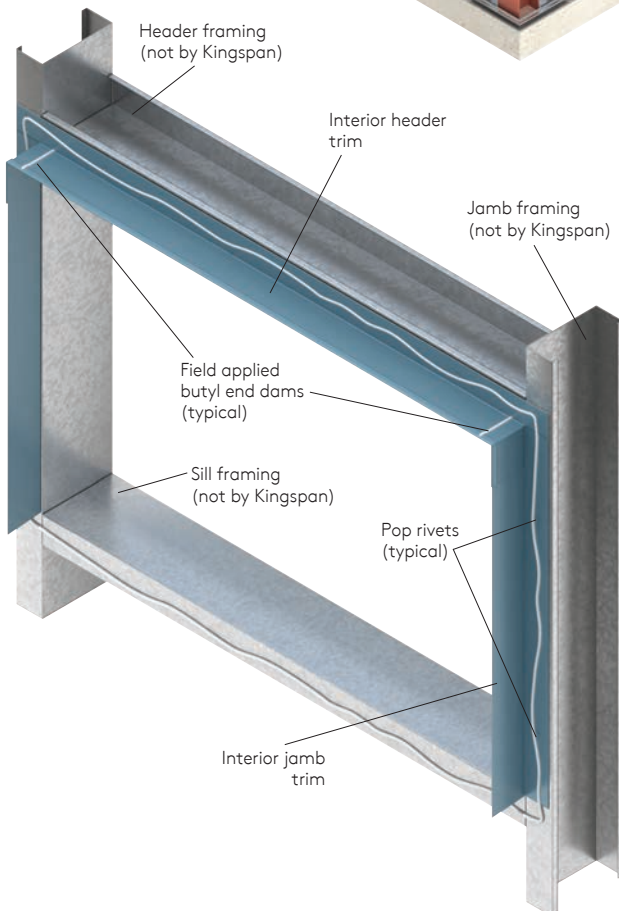
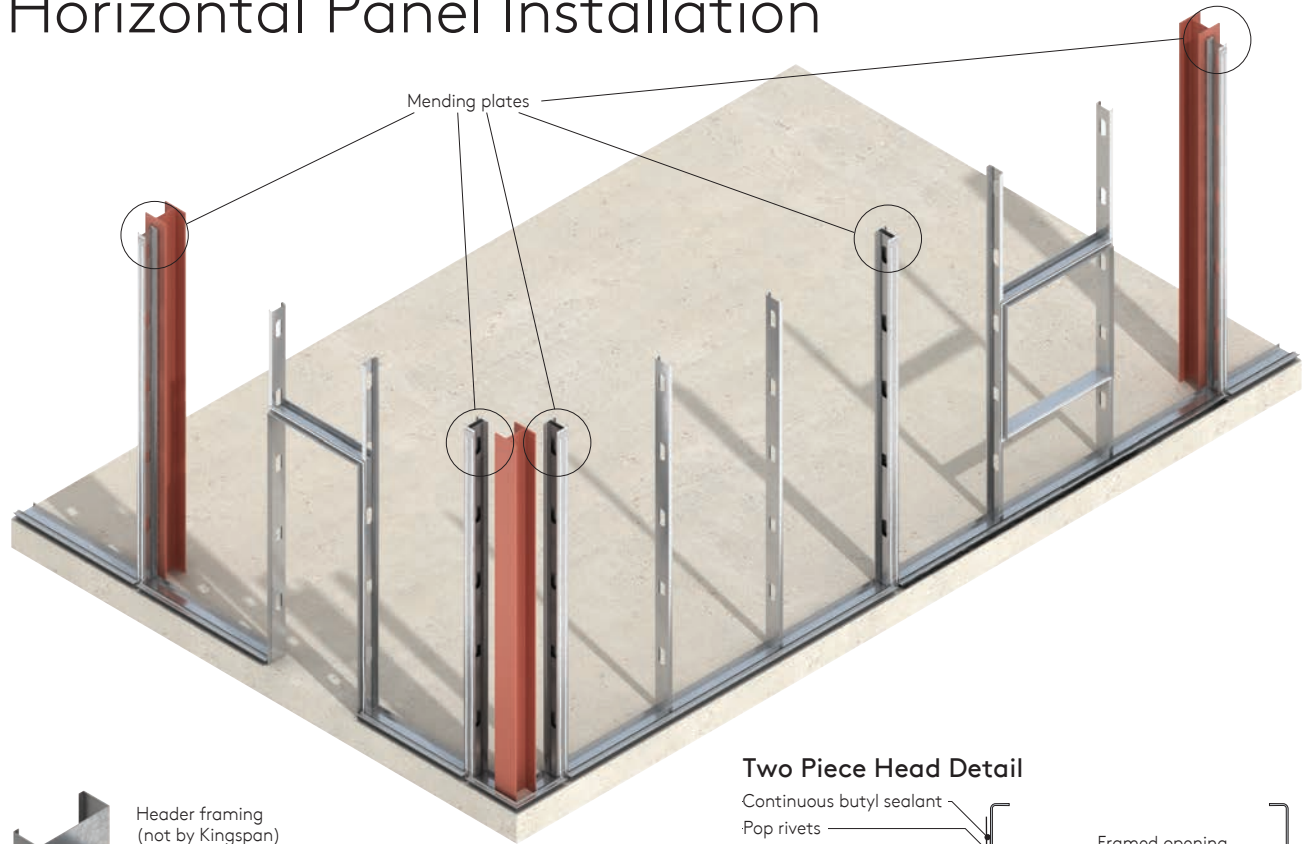

## Two Piece Head Detail

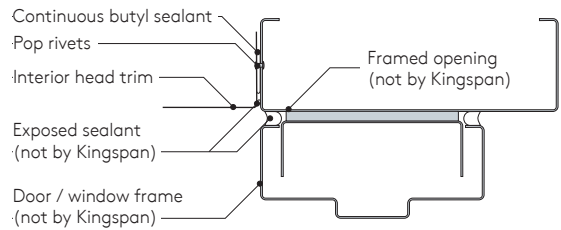

## Framed Opening Head Detail with Drip Edge

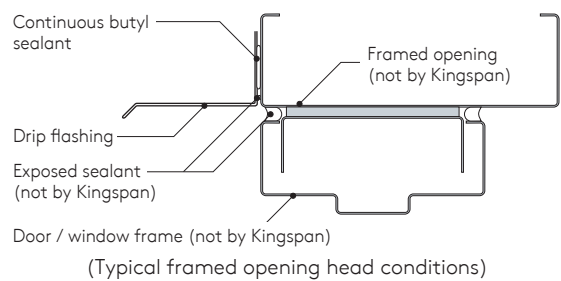

## Header with Extrusion Detail

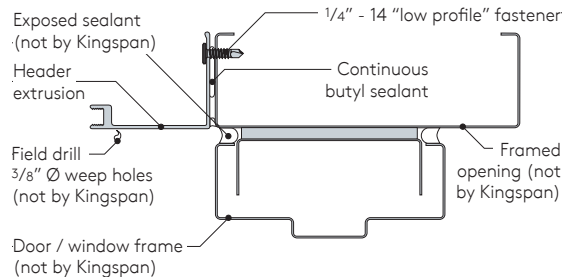

# Horizontal Panel Installation

## Panel Attachment at the Base

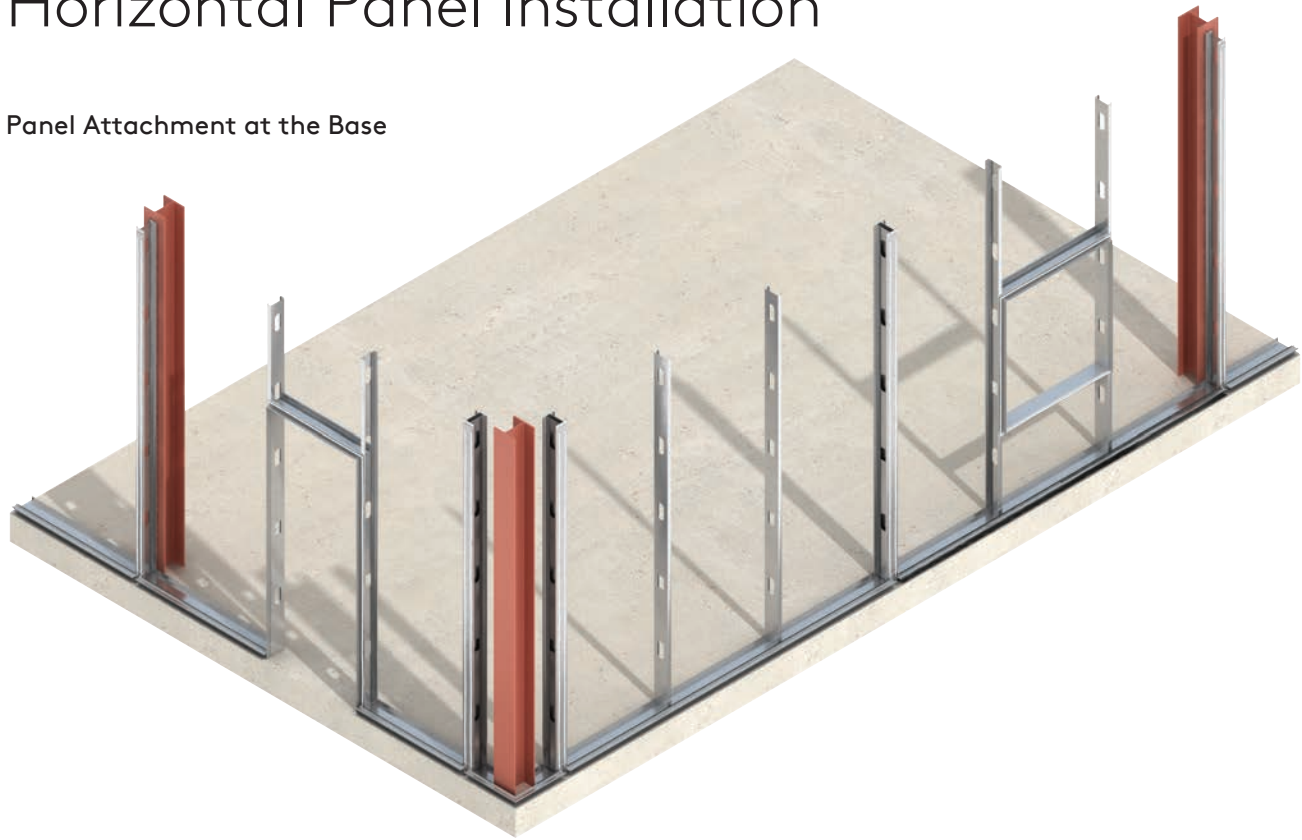

**D** Install base extrusion per project shop drawings. Extrusion must be level and set in butyl sealant.

**E** Base extrusion must be stopped short of vertical reveal locations as shown. Insert compressible foam closures per project details.

**F** Apply beads of butyl sealant on vertical mending plates as shown.

### Base Flush Detail

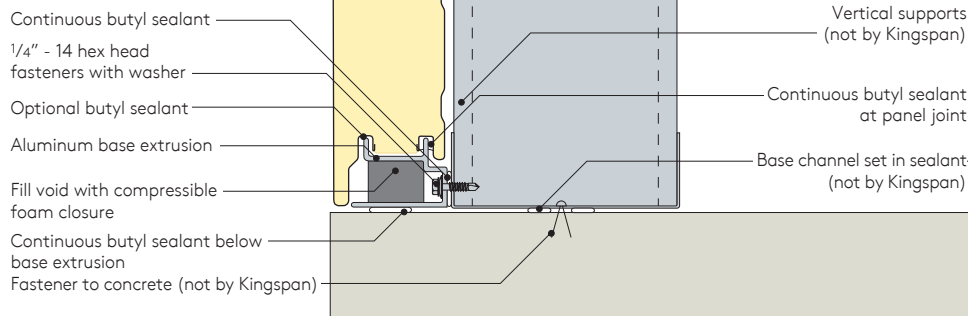

### "J" Base Overhang Detail

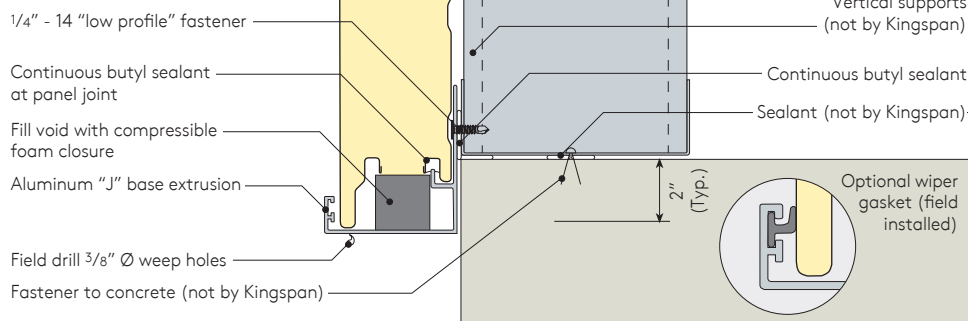

# Horizontal Panel Installation

## Base Flush Detail

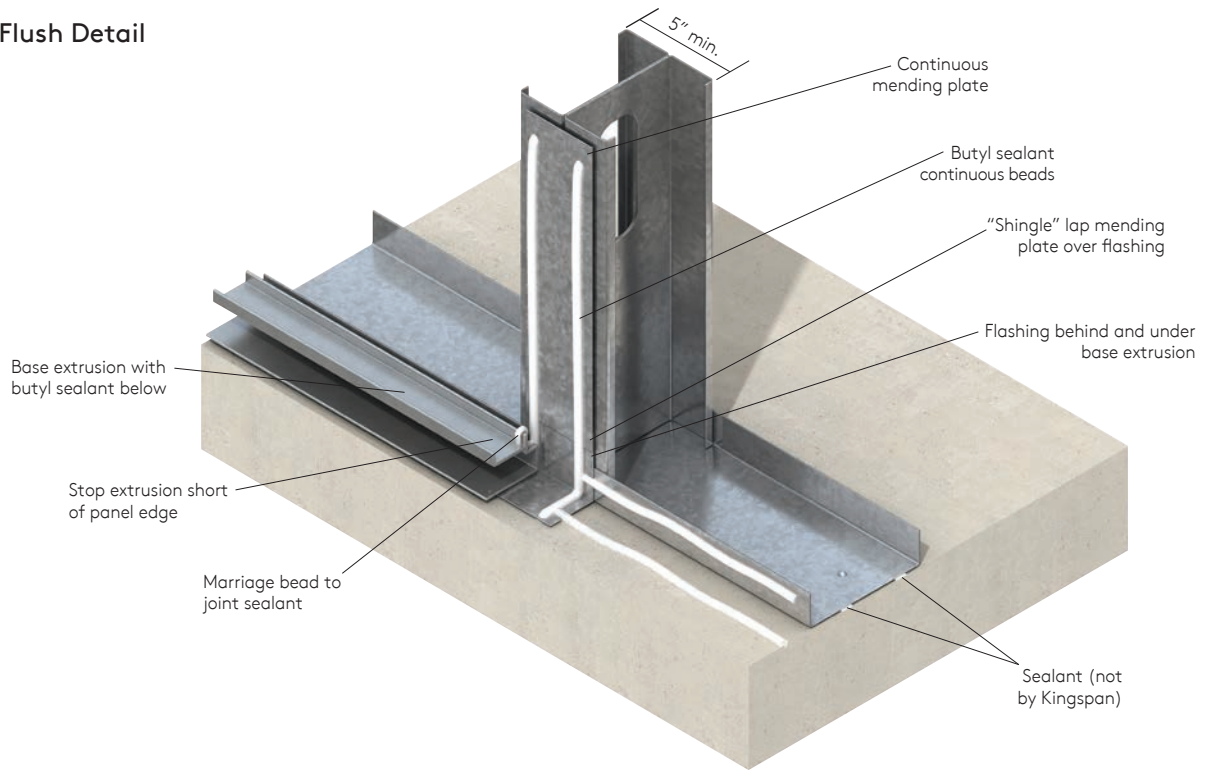

## "J" Base Overhang Detail

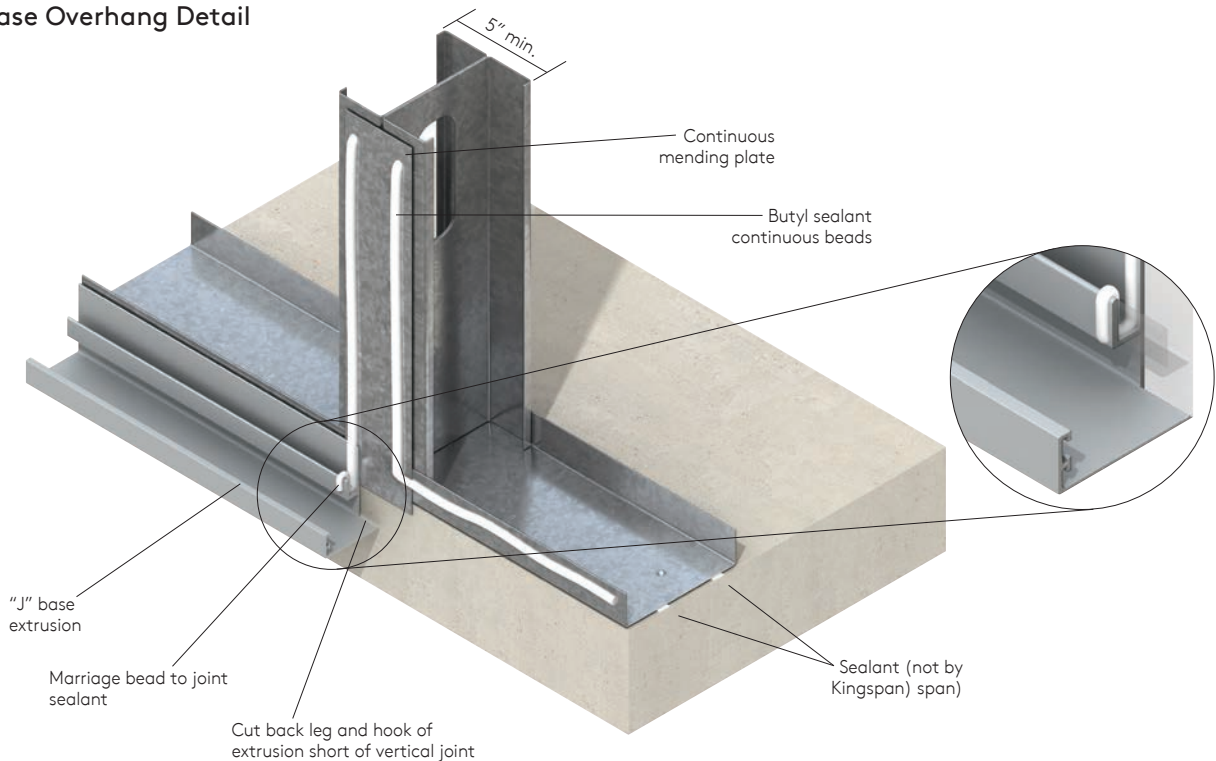

# Horizontal Panel Installation

## Prefabricated Corner Installation

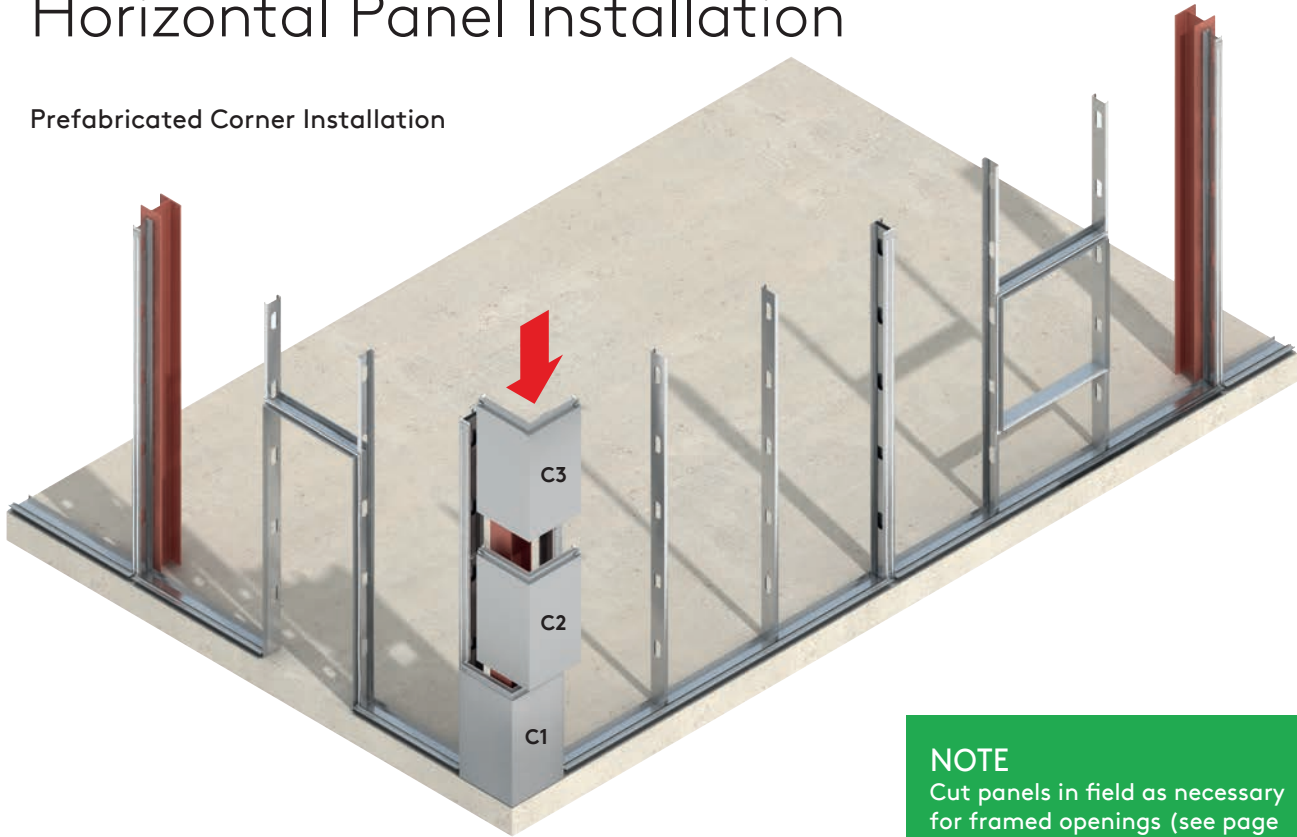

**NOTE**  
Cut panels in field as necessary for framed openings (see page 14).

**G** Starting from a corner, locate reveal centerline previously marked on first vertical mending plate.

**H** Using a level, mark this plate to indicate edges of vertical reveal joint (one half the dimension of vertical reveal on each side of centerline).

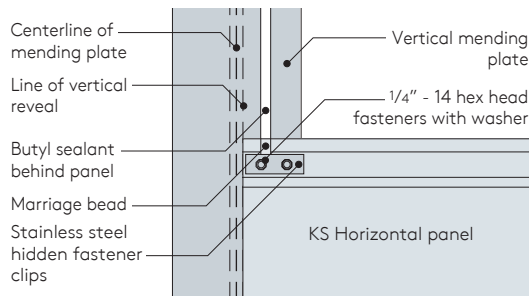

(See Vertical Joint Assembly - Panel P1)

**NOTE**  
Consult with Kingspan Technical Department for allowable panel loads, spans and fastening pattern.

**NOTE**  
Panel installation may begin with either the corners or straight wall panels. Site measurements verifying dimensions of corner panels should be made prior to corner panel fabrication.  
For large, complex structures or those with dimensional errors, it is typical to set the straight panels first, then install folded corners (as shown in this guide).  
For simpler buildings it is typical to set the corner panels prior to the straight wall panels. Proceed directly to steps P-S, then return to complete steps I-O.

# Horizontal Panel Installation

- I** Set the factory bent corner panel (**C1**) into the base extrusion. Be sure to position the panel between the vertical joint centers, level, and fasten as required.

**NOTE**  
Steel must be plumb and level for proper fit of factory bent corner panels.

- J** Set the factory bent corner panel (**C1**) into the base extrusion. Be sure to position the panel between the vertical joint centers, level, and fasten as required.
- K** Lower factory bent corner panel (**C2**) into position using vertical joint reveals as a guide. Firmly seat panel to assure proper sealant contact. Level panel as required.
- L** Install butyl sealant marriage bead from mending plate to interior male joint.
- Repeat steps R and S for panel **C3**.

## Factory Bent (preformed) Corner Panel

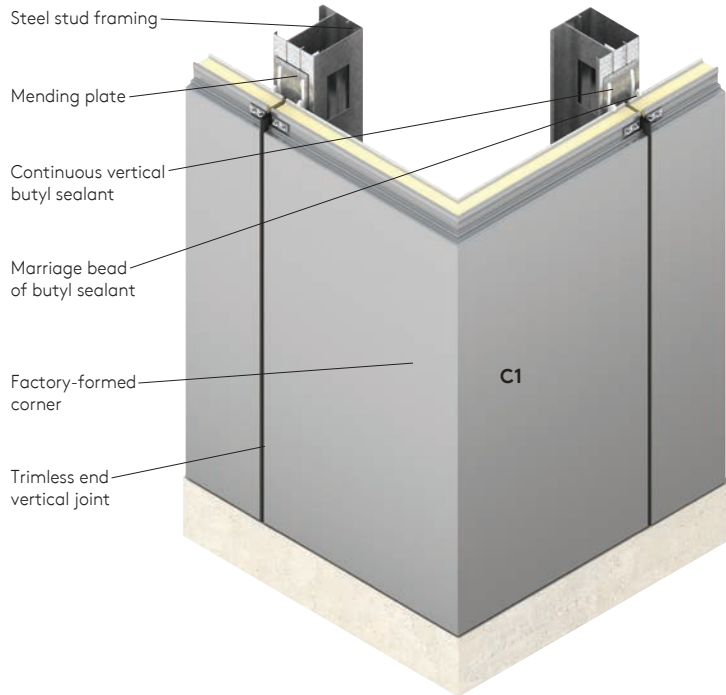

## Outside Corner - Factory Folded Detail

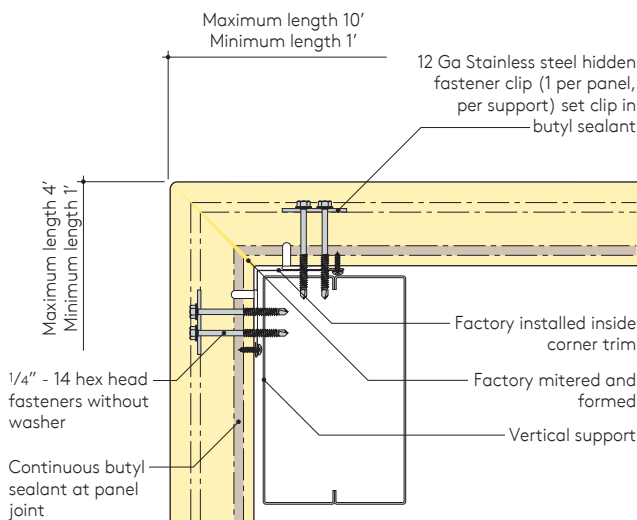

Factory folded corners and trimless ends available with Granitstone®, Micro-Rib, Mini Micro-Rib and Optimo® panels.

## Outside Corner with Extrusion Detail

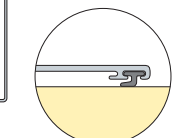
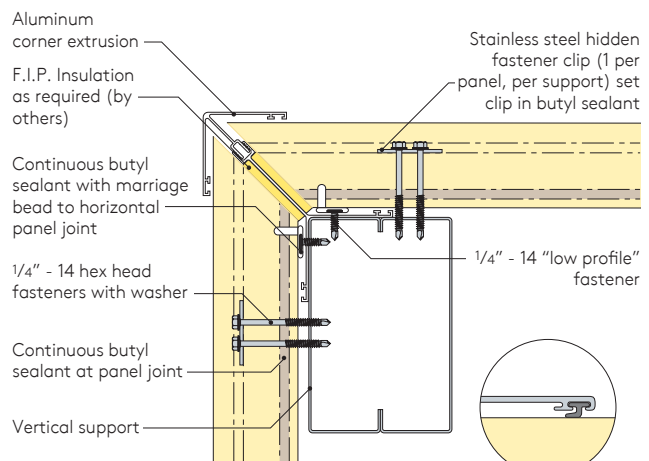

Optional wiper gasket (field installed)

# Horizontal Panel Installation

## Panel Installation - Bottom Row

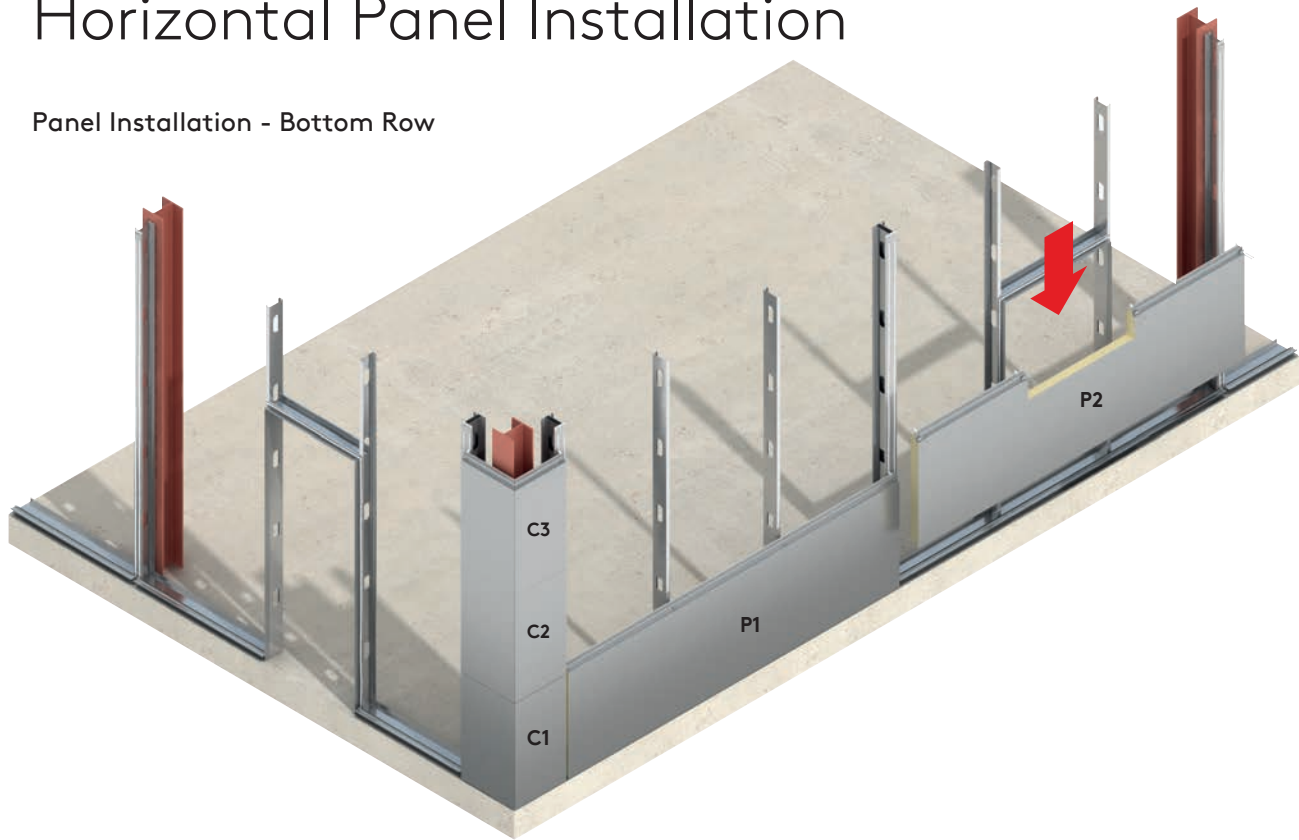

- M** Set panel **P1** as shown. Line up left edge of panel with right side reveal mark on mending plate as shown.
- N** Fasten into supporting steel with appropriate clips and  $\frac{1}{4}$ " - 14 fasteners as indicated on shop drawings.
- O** Once panel is secured, apply butyl sealant over the interior male lip at both panel ends to create a marriage bead to the sealant on the vertical mending plate.
- P** Place panel **P2** in position. Verify that the vertical edges of the panel are lined up with reveal marks on mending plate.

### Vertical Joint Assembly at Corner- Panel P1

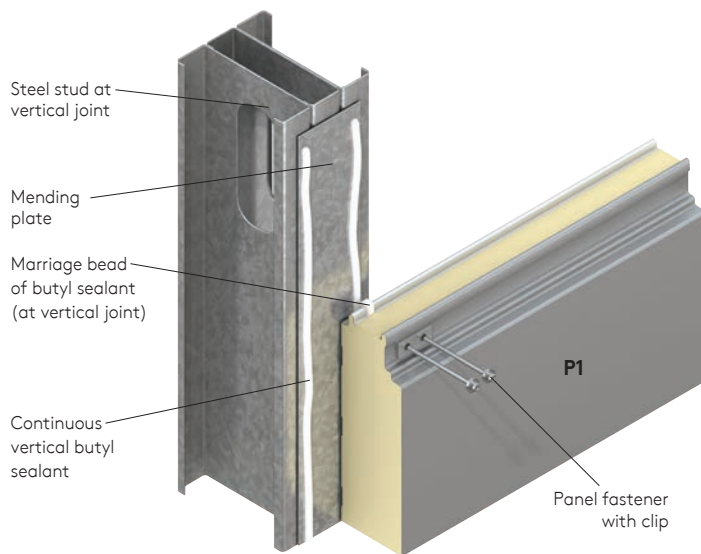

# Horizontal Panel Installation

Vertical Joint Assembly at Corner (P1, P3)

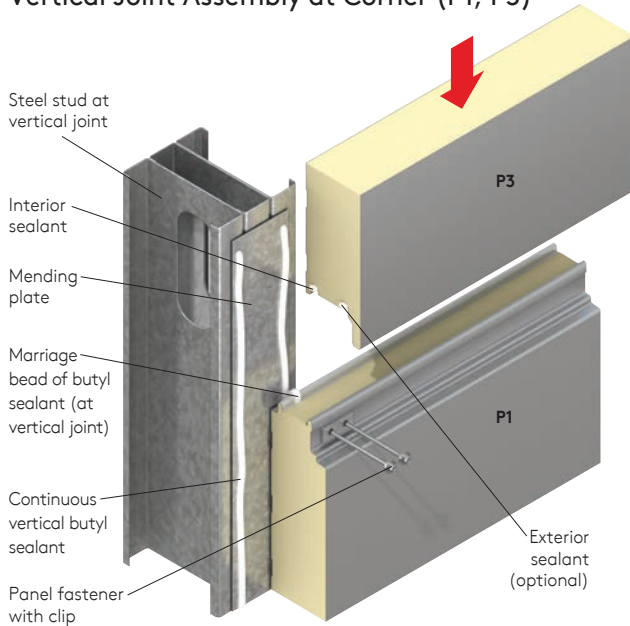

Intermediate Fastener Position

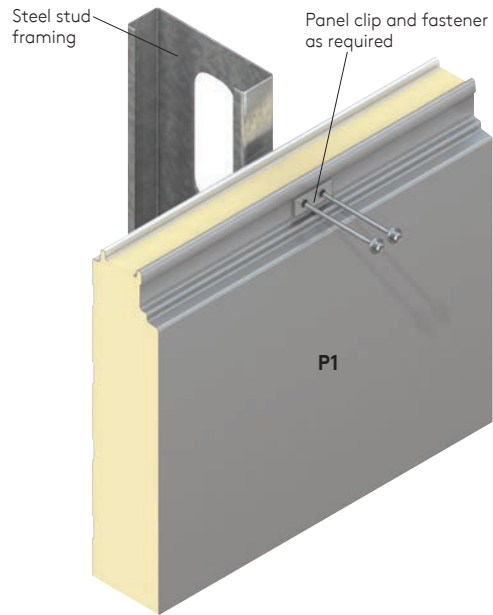

Vertical Joint Assembly

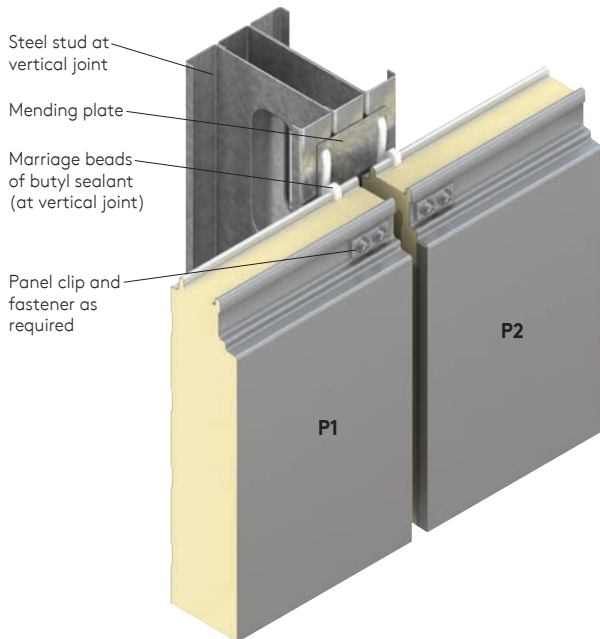

Vertical Joint Options

Trimless End Joint with Gasket Assembly

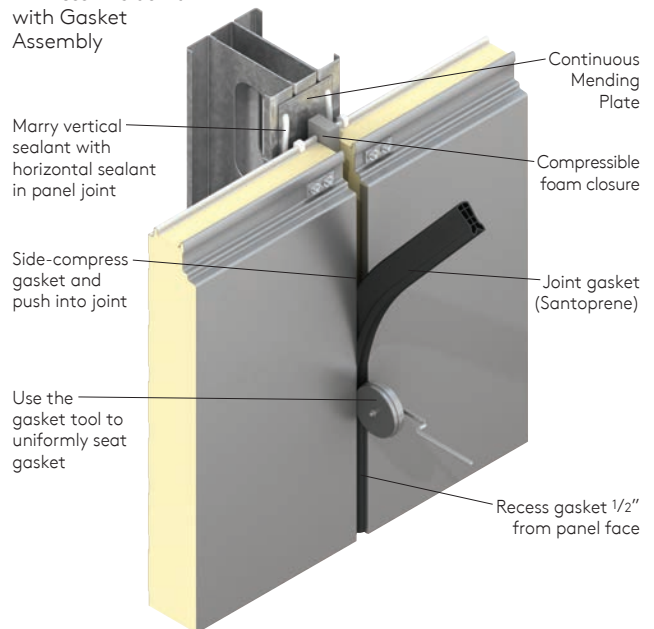

**CAUTION**

Do not over-tighten fasteners as damage to the panel core as well as facings will result.



**NOTE**

Verify panels are completely engaged, with proper sealant contact and joint reveals.

# Horizontal Panel Installation

Intermediate Panel Fastener Detail

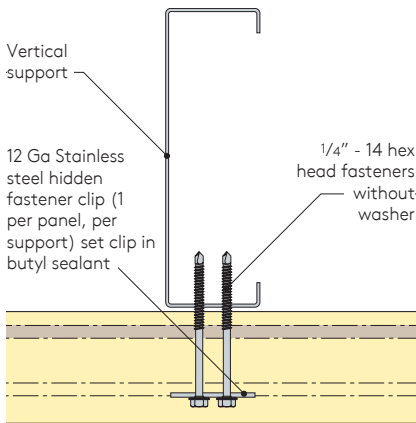

Horizontal Expanded Panel Joint Section Detail

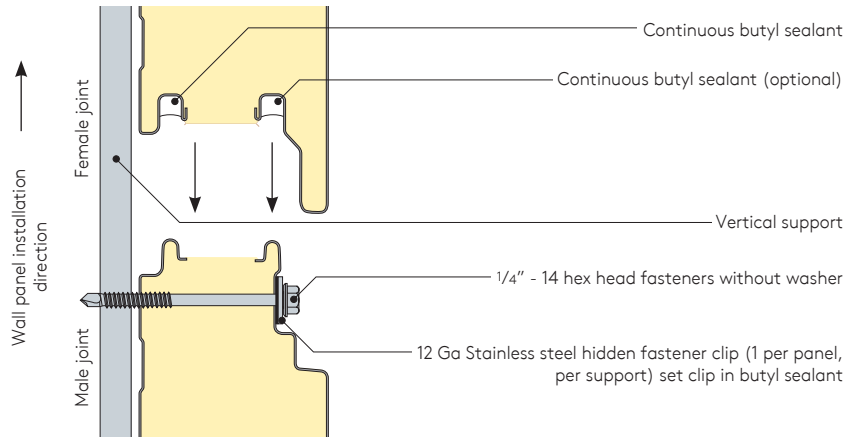

- Q** Complete installation of base course of panels.
- R** Install first column of panels bottom to top using the same procedures. (Panels **P3-P4**).

**NOTE**  
Vertical support framing may vary. See page 69 for alternate condition.

**NOTE**  
Many horizontal panel applications use "trimless" panel ends and factory bent corner panels. As a result, most installers prefer to set the entire base course of panels first. This allows field checking of critical vertical reveal locations.

**NOTE**  
Slight deviations in panel length should be accommodated by sliding the panel horizontally, so that half the difference shows up on the reveal to the left, half on the reveal to the right. This minimizes "sawtoothing".

Horizontal Panel Joint Detail

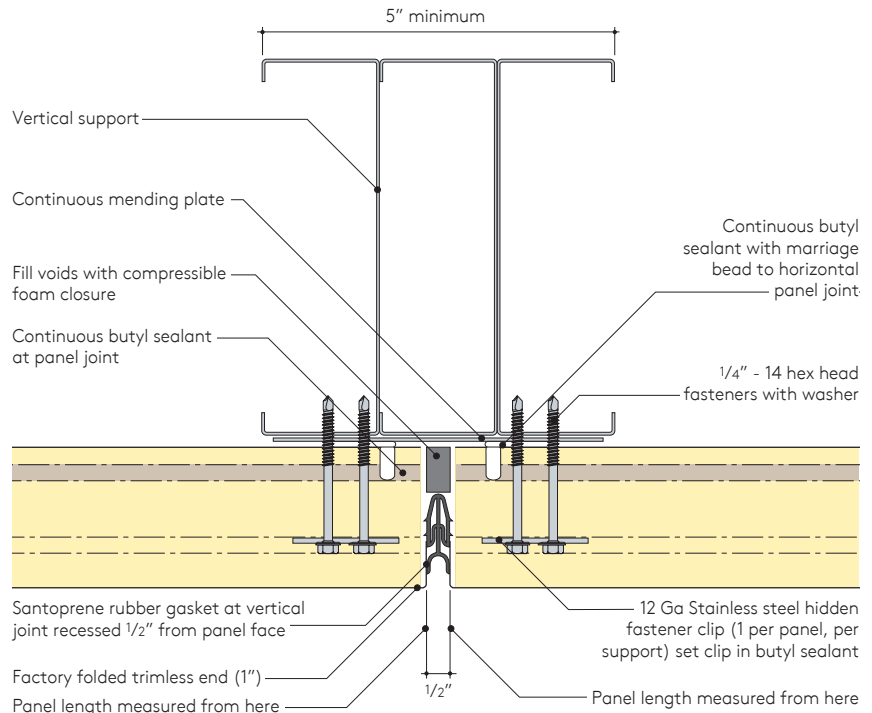

Trimless ends available with Granitstone®, Micro-Rib, Mini Micro-Rib and Optimo® panels.



# Horizontal Panel Installation

## Panel Installation - Vertical Stacking

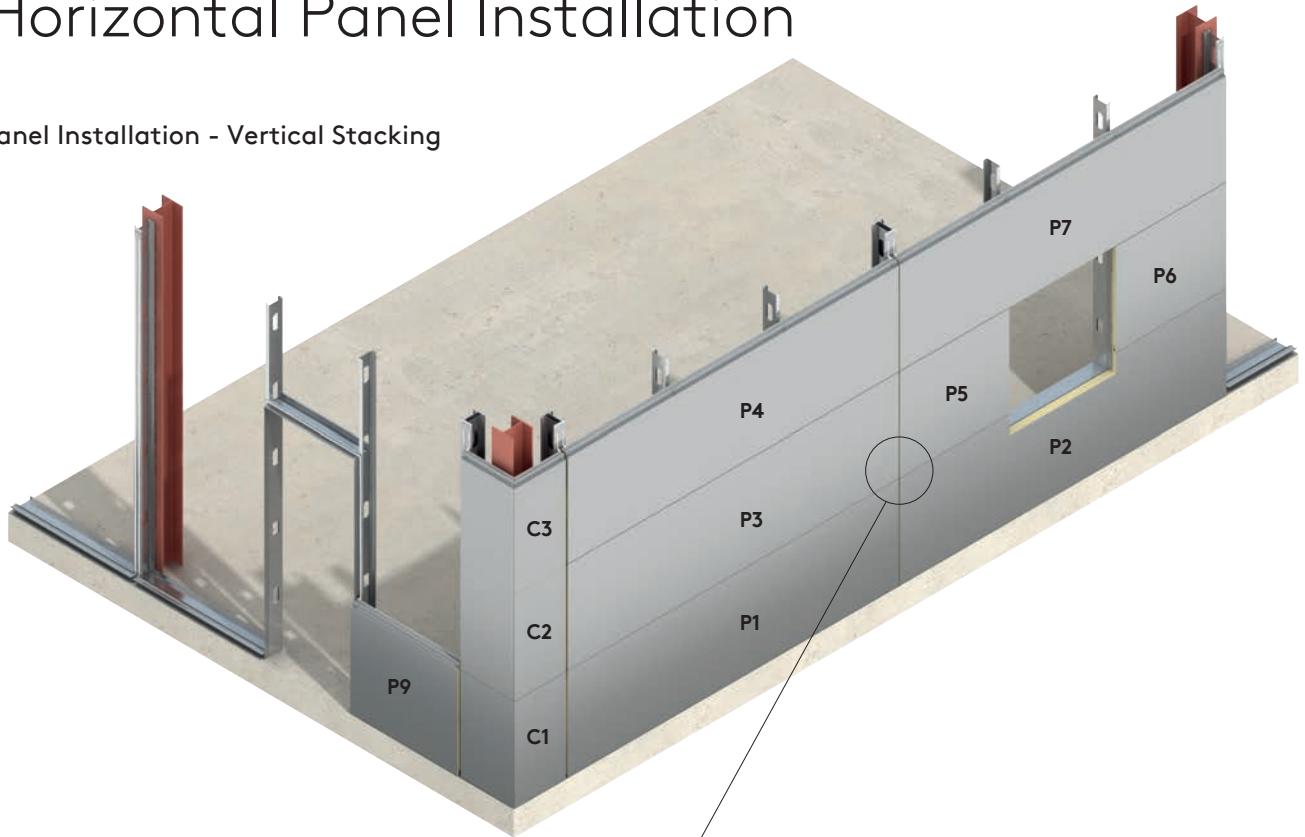

### Aluminum Top Hat Joint Assembly

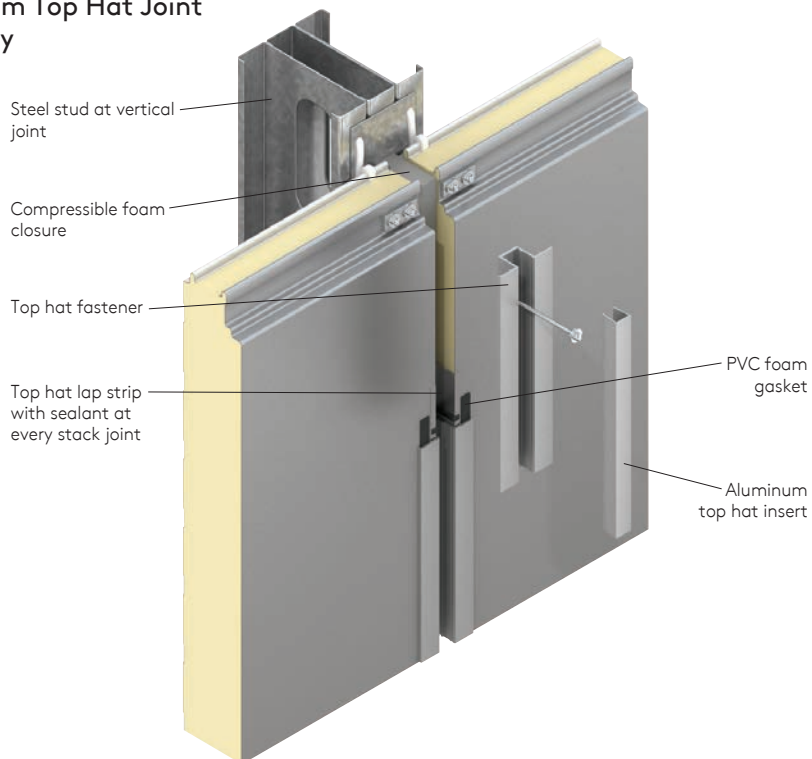

# Horizontal Panel Installation

Assembly Sequence

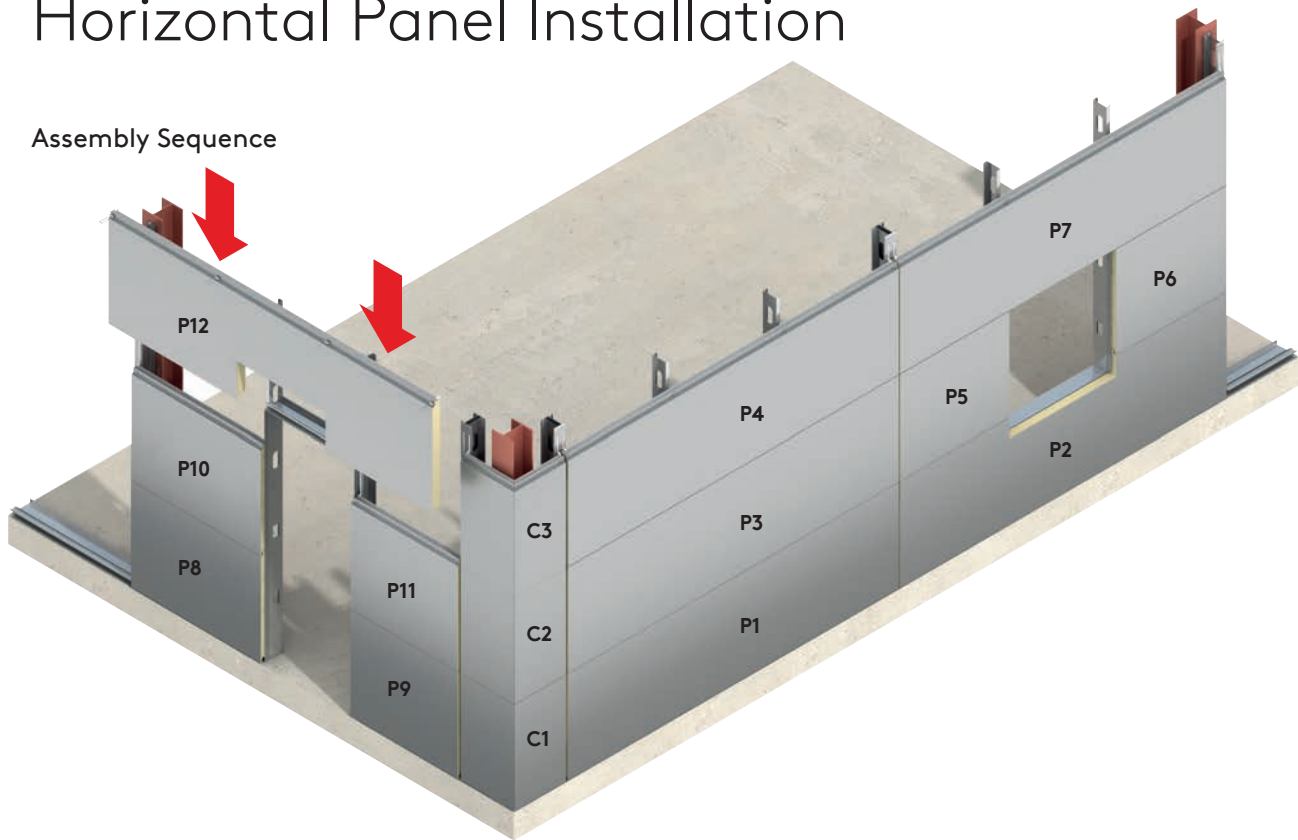

**S** Once the first building elevation is completed (**P1-P7**), start around the corner on next elevation using the same sequence and method (**P8-12**).

**NOTE**  
To minimize panel cutting, panel lengths should be pre-determined to align with framed opening jambs.

**NOTE**  
Numbers indicate order of panel installation.

# Horizontal Panel Installation

## Vertical Joint Options

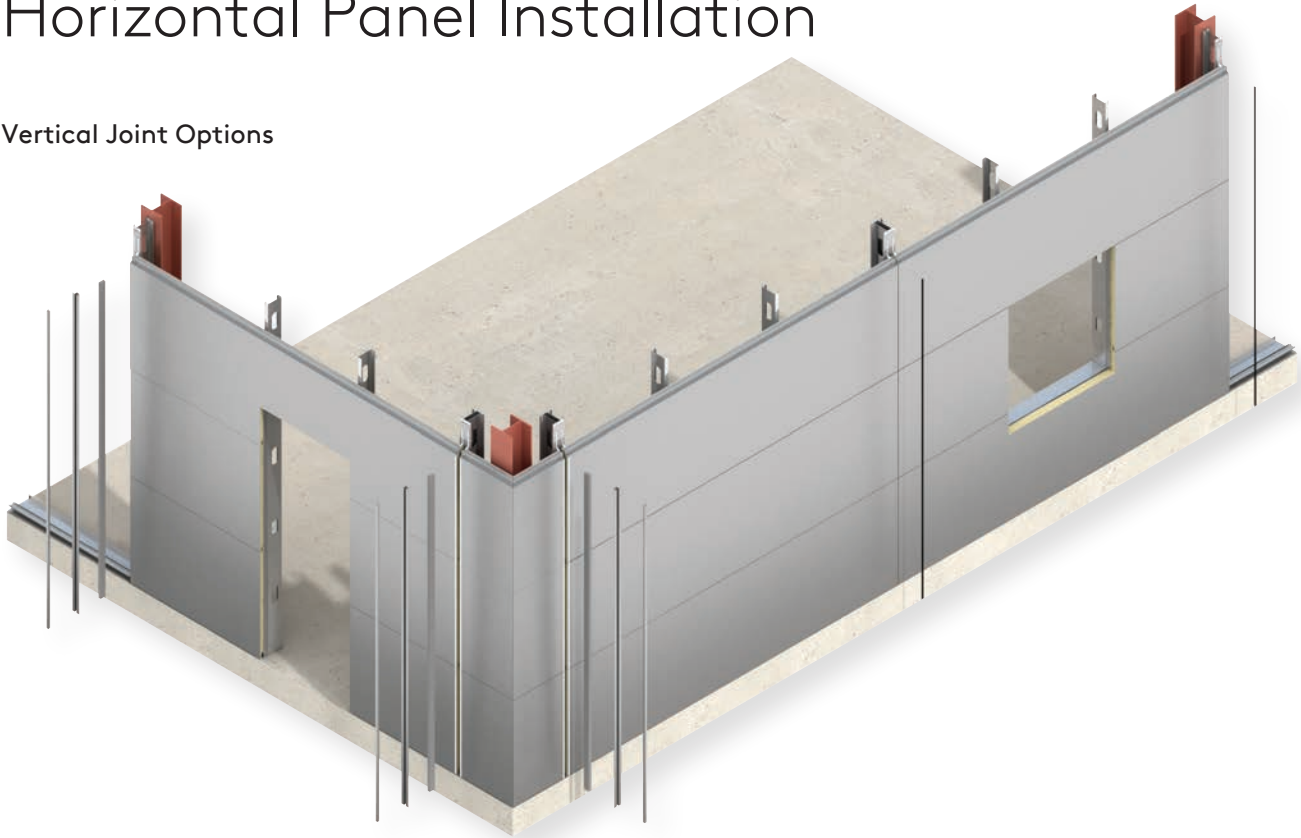

## Vertical Joint with Trim Detail

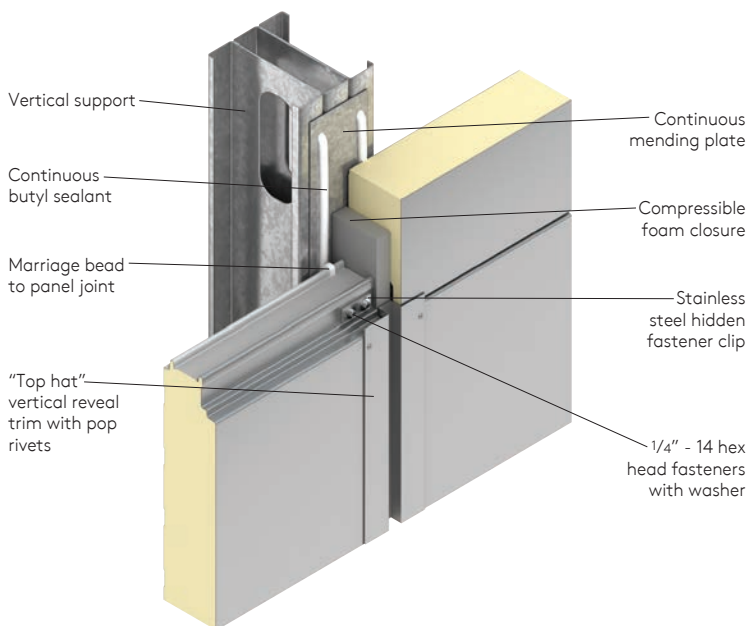

**T** Verify vertical joint treatment per project shop drawings. For trimless ends, insert compressible foam closure until firmly seated against mending plate, then install Santoprene joint gasket as shown.

For aluminum extrusion assemblies, insert compressible foam closure until firmly seated against mending plate, then install "Top-Hat" extrusion as shown. Use matching color lap strips at every extrusion butt joint.

(See page 85 for "top hat" lap strip details).

# Horizontal Panel Installation

## Framed Opening Trim / Extrusion Installation

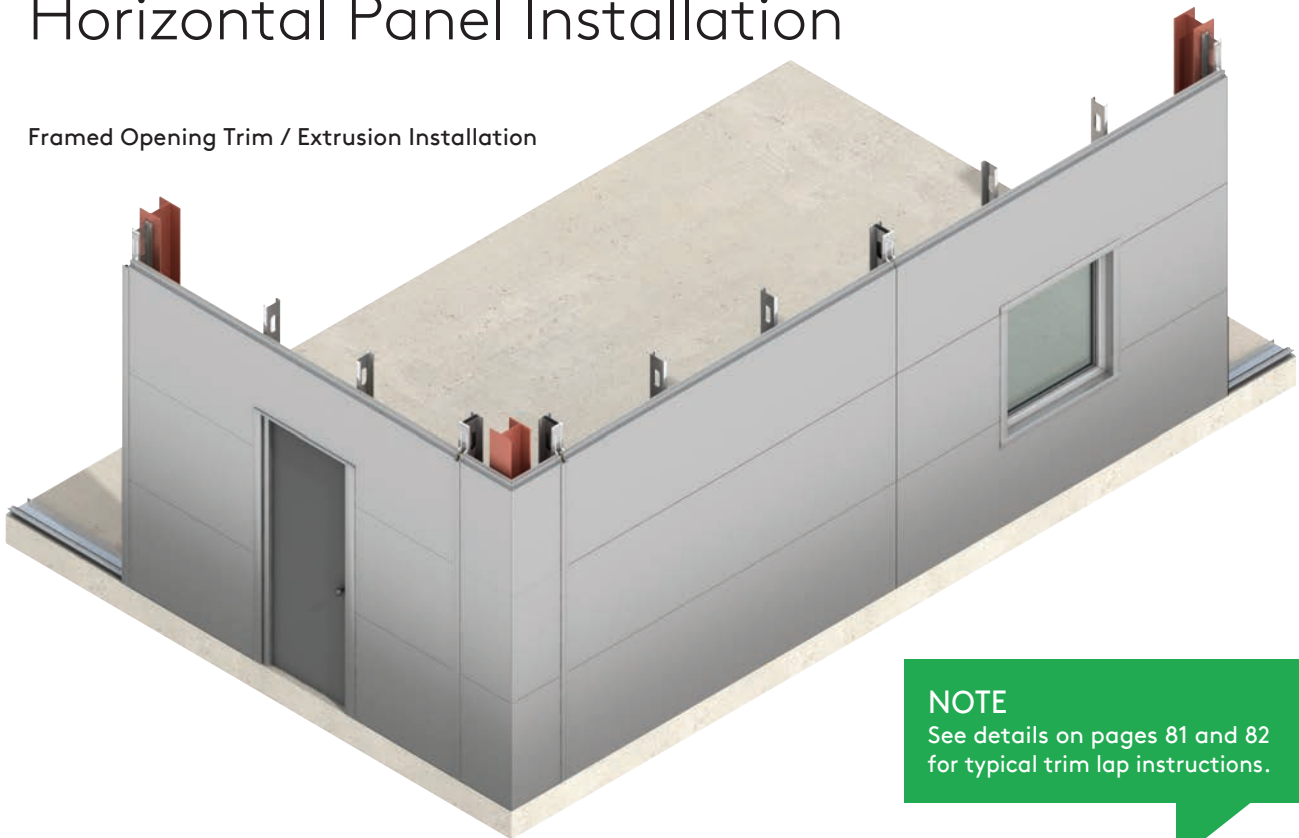

**NOTE**  
See details on pages 81 and 82  
for typical trim lap instructions.

- U** Install exterior framed opening trims and extrusions as required.
- V** Seal with exposed sealants where indicated on shop drawings. Field drill weep holes as indicated on shop drawings.

### Window Assembly Detail - Trim

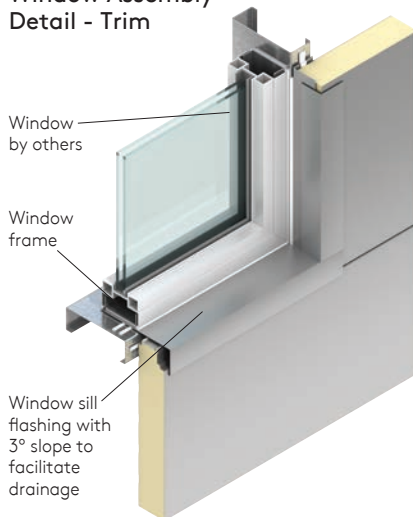

### Door Assembly Detail - Trim

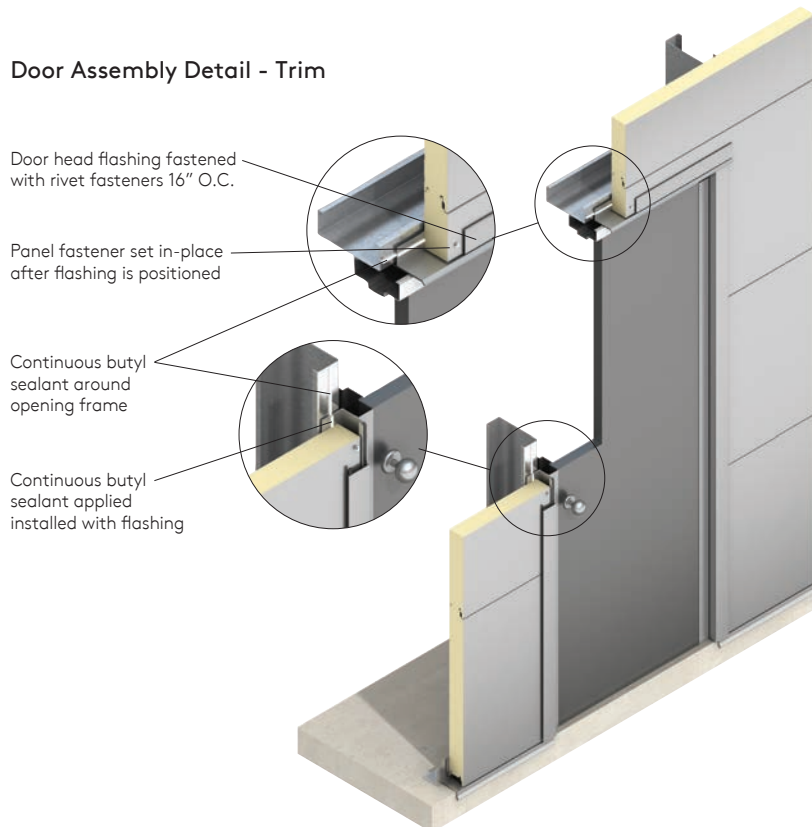

# Horizontal Panel Installation

## Framed Opening Two Piece Jamb Detail

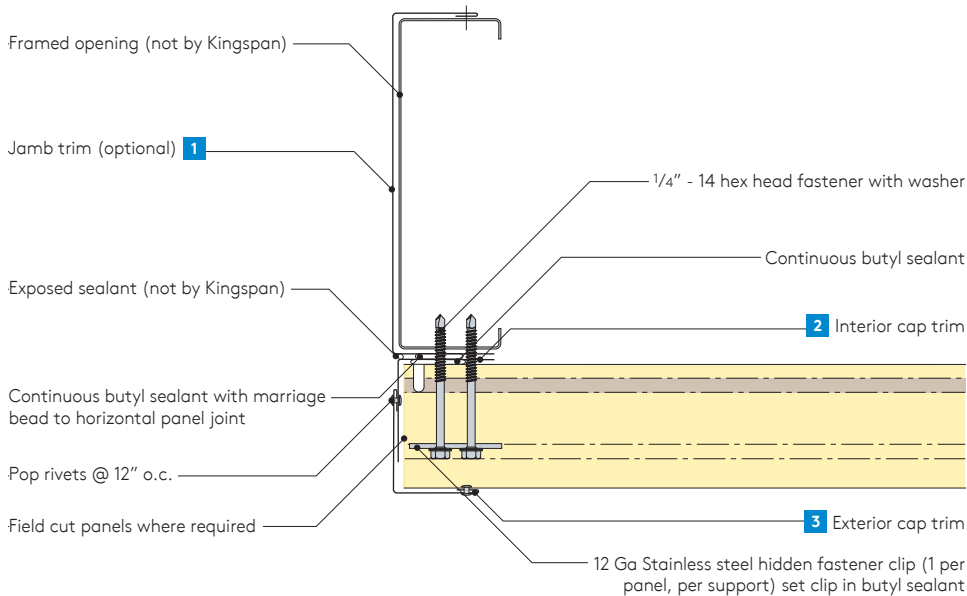

Trim installation sequence:

- 1 Jamb trim (optional) & all applicable sealants.
- 2 Interior cap trim & all applicable sealants prior to installing the panel and through fasteners.
- 3 Exterior cap trim.

## Framed Opening Head with Drip Flashing Details

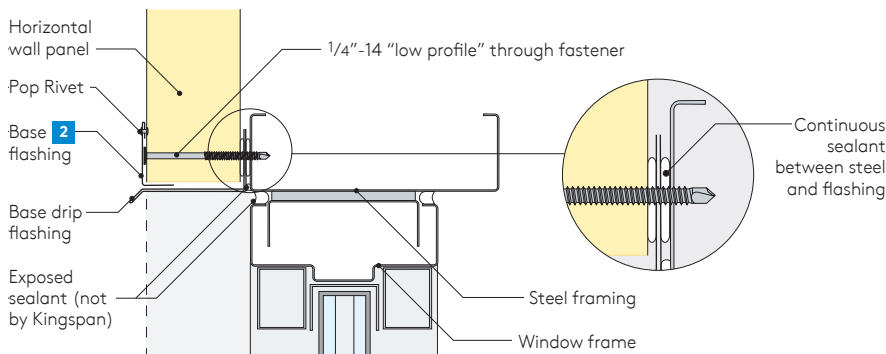

Trim installation sequence:

- 1 Drip flashing & all applicable sealants prior to installing the panel and through fasteners.
- 2 Base flashing.

**NOTE**  
Field bend ends of sill trim upwards (see page 82 for recommended trim installation sequence).

## Framed Opening One Piece Sill Details

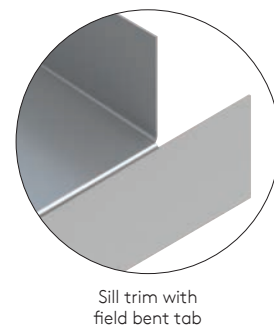
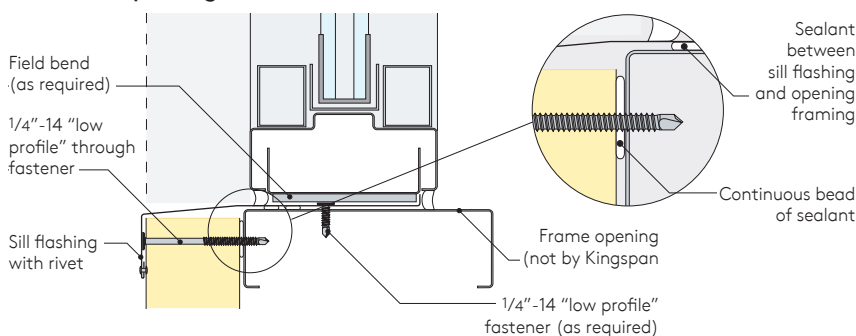

# Horizontal Panel Installation

## Framed Opening Assembly Details - Extrusions

### Jamb with Extrusion Detail

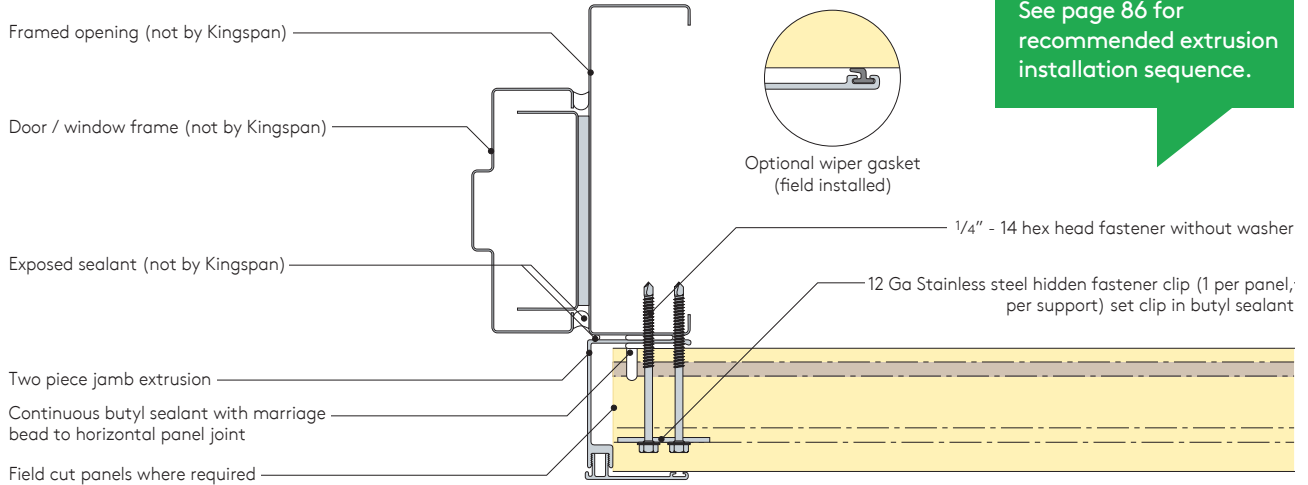

**NOTE**  
See page 86 for recommended extrusion installation sequence.

### Header with Extrusion Detail

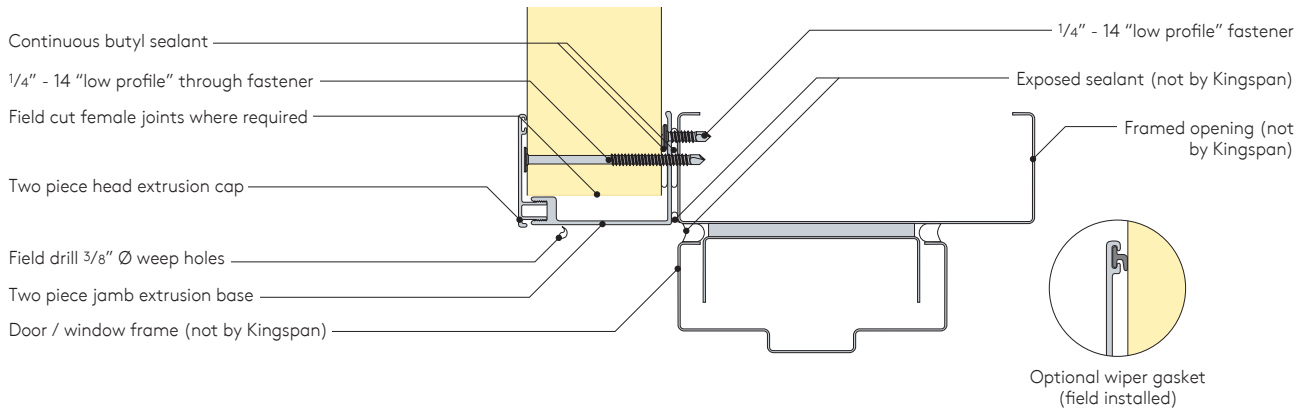

### Sill with Extrusion Detail

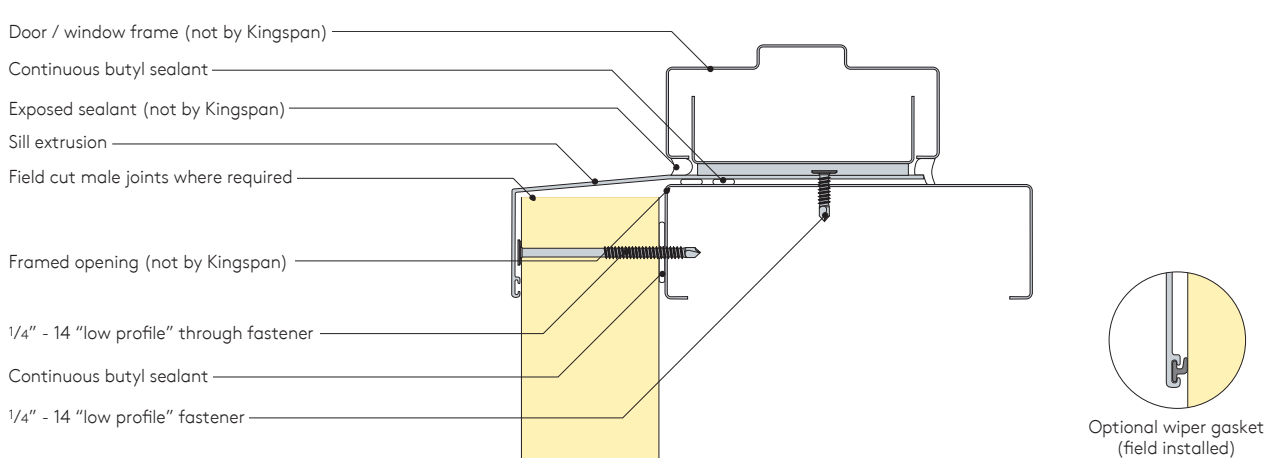

# Horizontal Construction Details

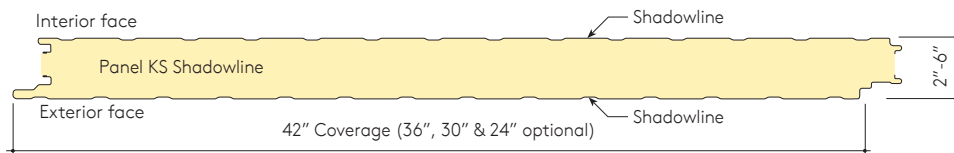
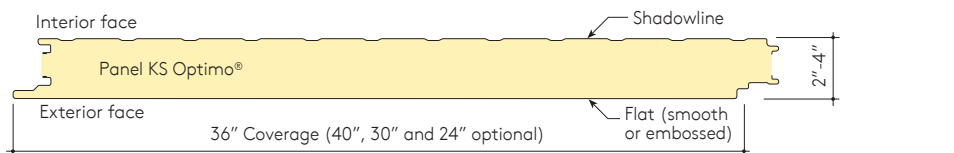
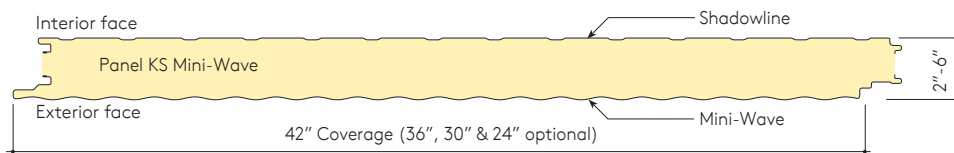
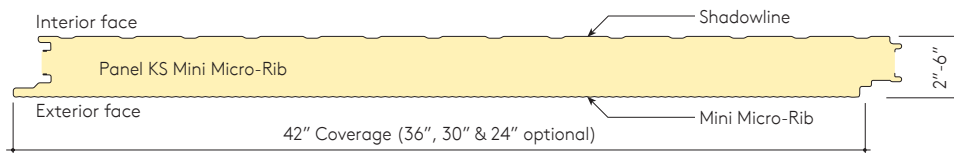
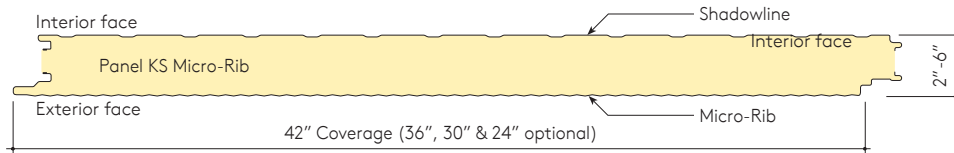
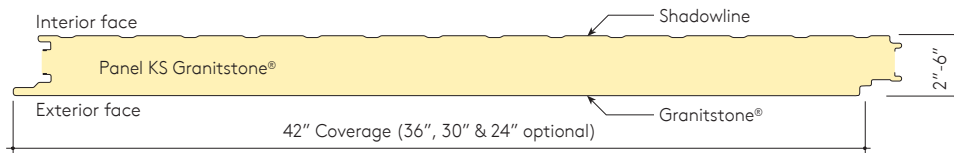
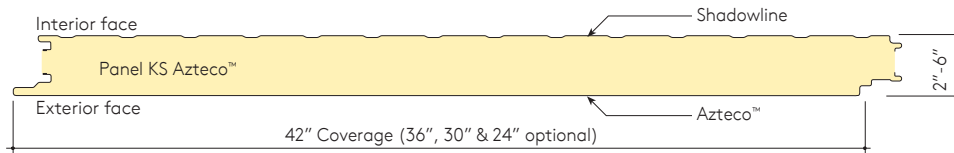

# Horizontal Construction Details

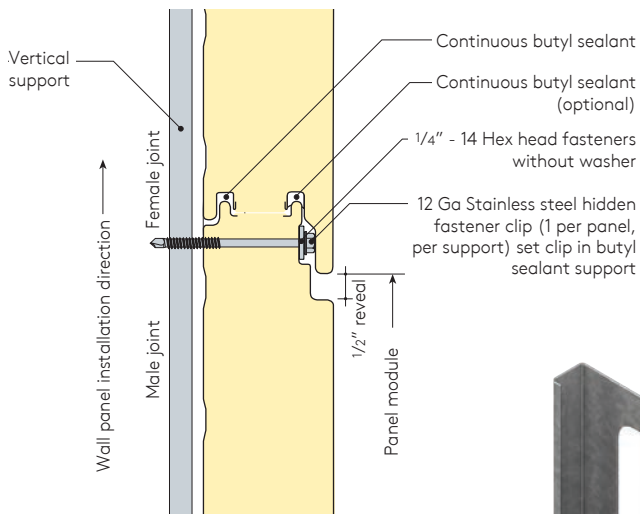
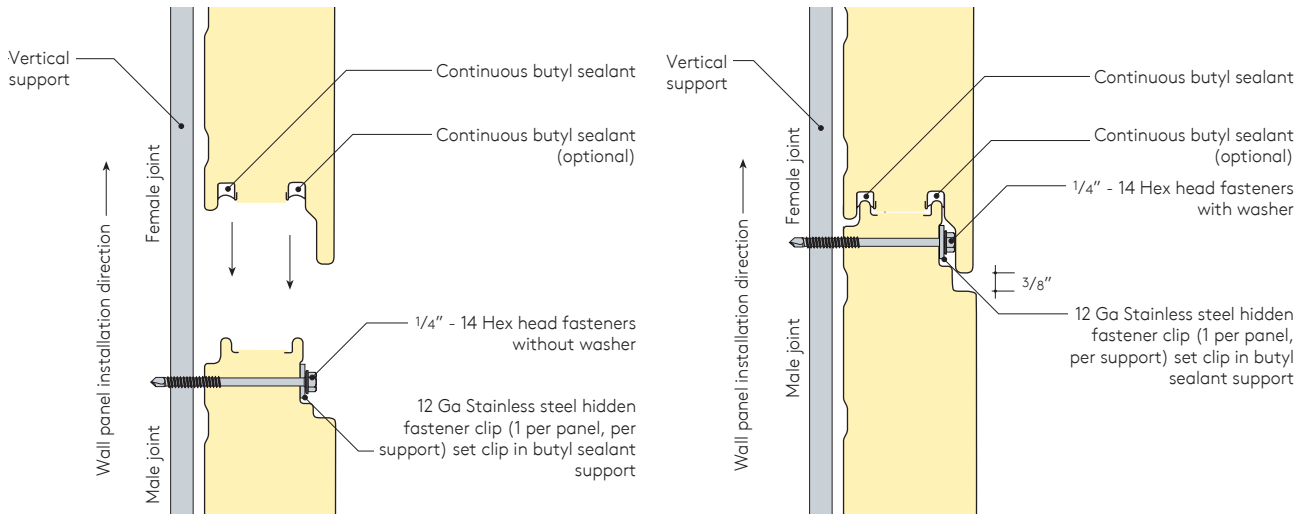

**NOTE**  
Contact Kingspan Technical Services for specific project fastening recommendations.



# Horizontal Construction Details

## Vertical Joint with Trim Detail

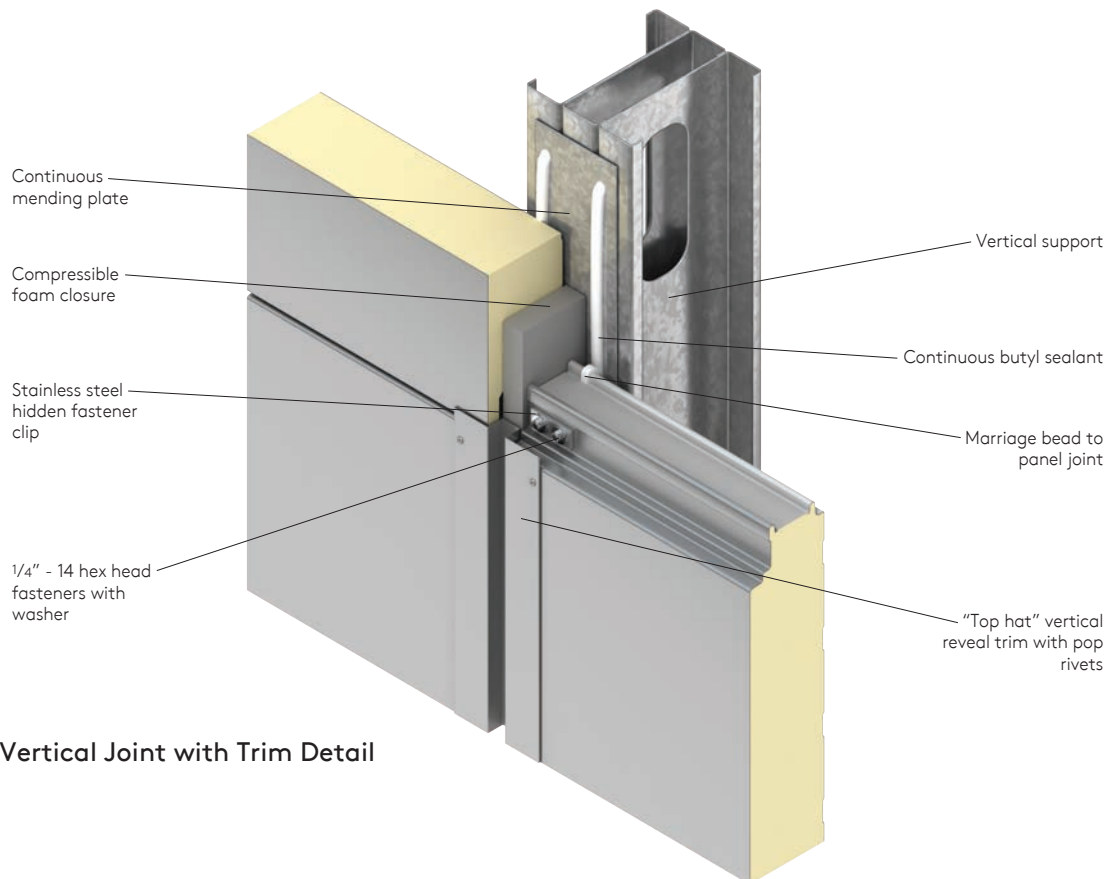
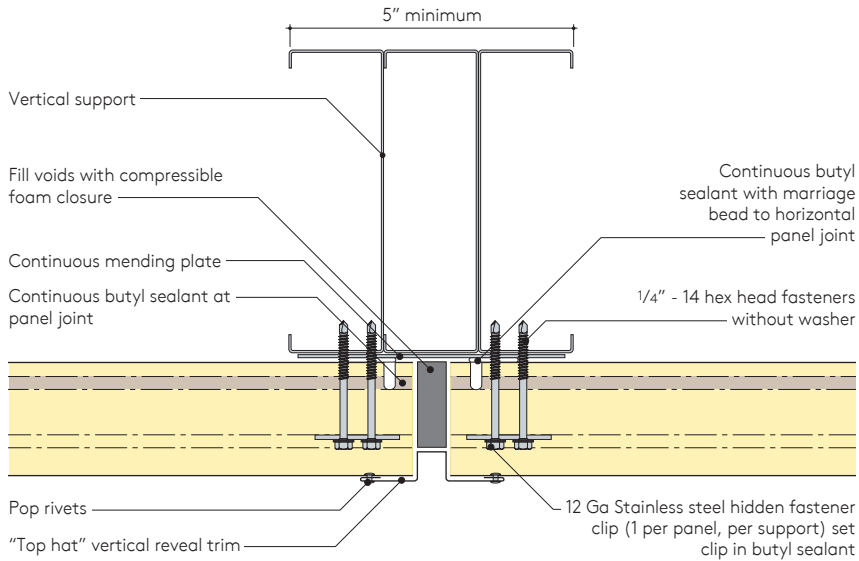

Vertical Joint with Trim Detail

# Horizontal Construction Details

## Vertical Joint with Trimless End Detail

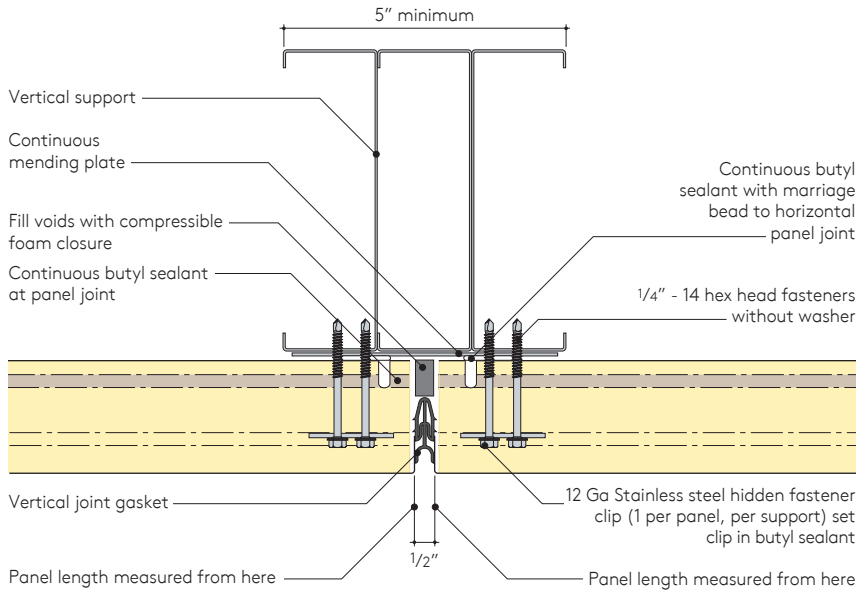

Trimless ends available with Granitstone®, Micro-Rib, Mini Micro-Rib and Optimo® panels.

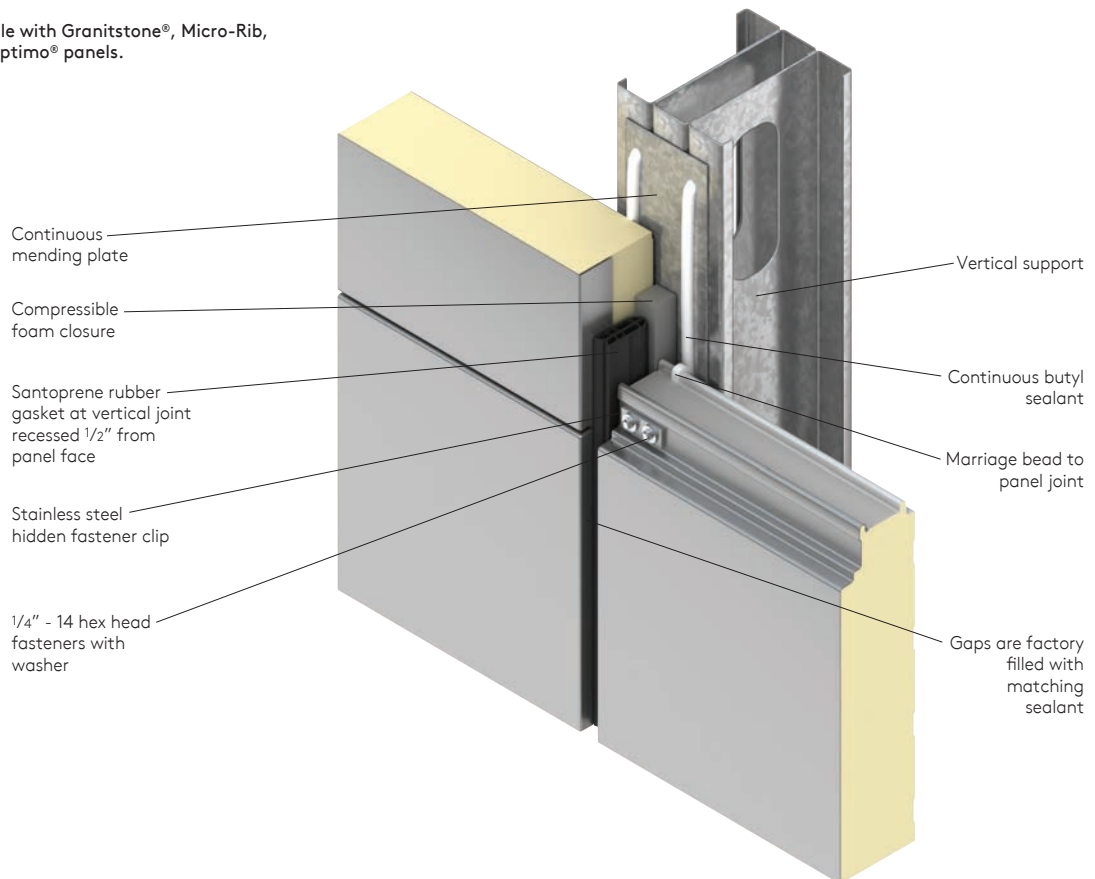

# Horizontal Construction Details

## Vertical Joint with Extrusion Detail

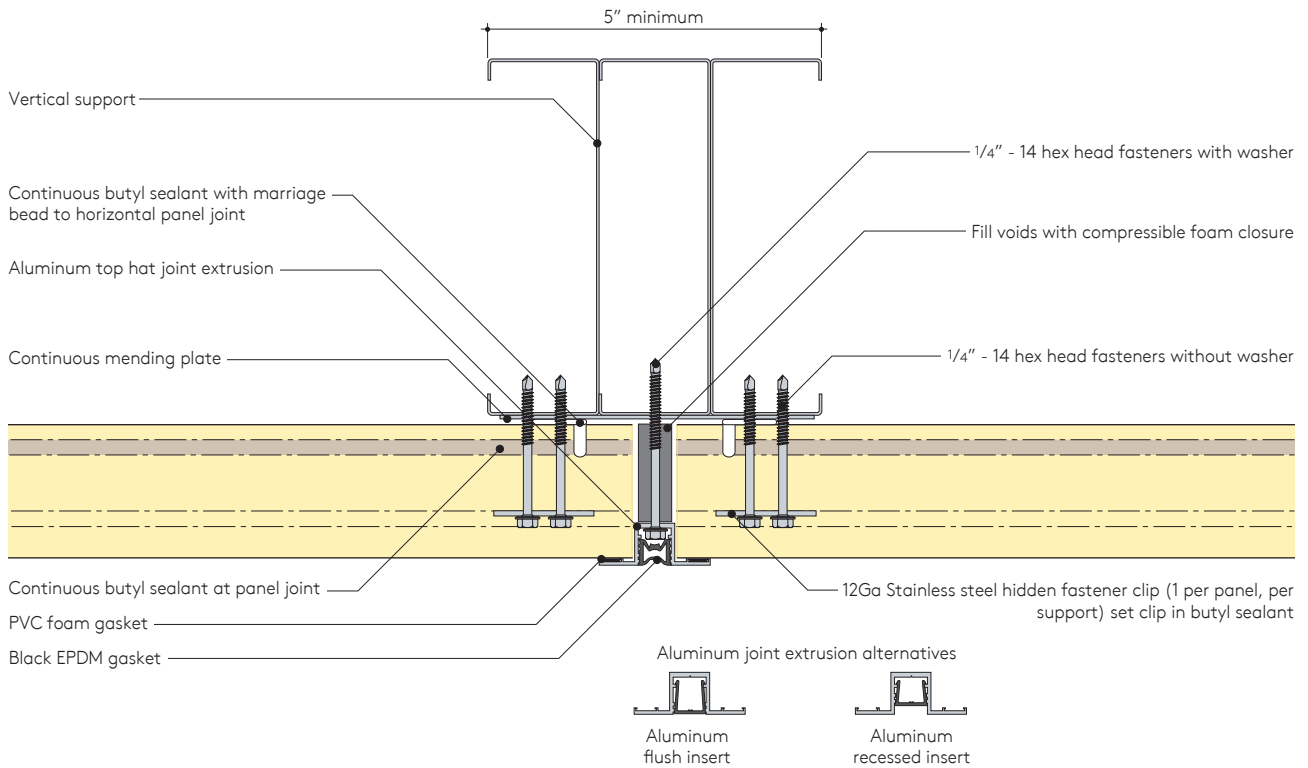

## Vertical joint - Alternate Framing Detail

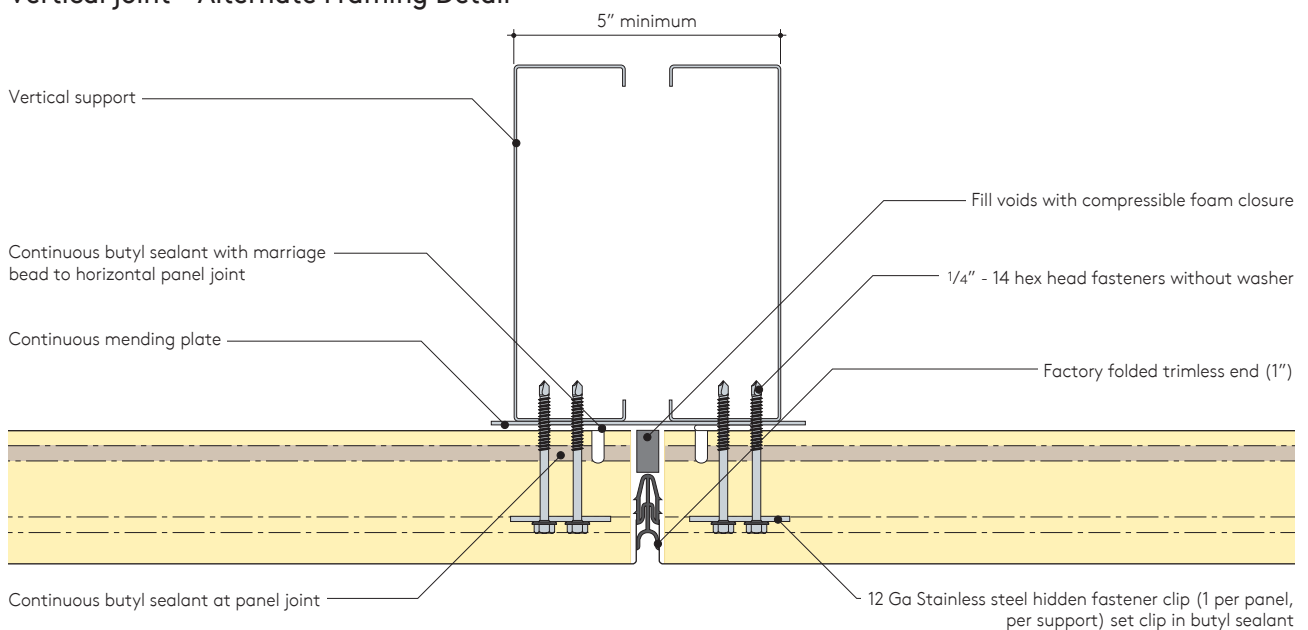

Trimless ends available with Granitstone®, Micro-Rib, Mini Micro-Rib and Optimo® panels.

# Horizontal Construction Details

## Base Flush Detail

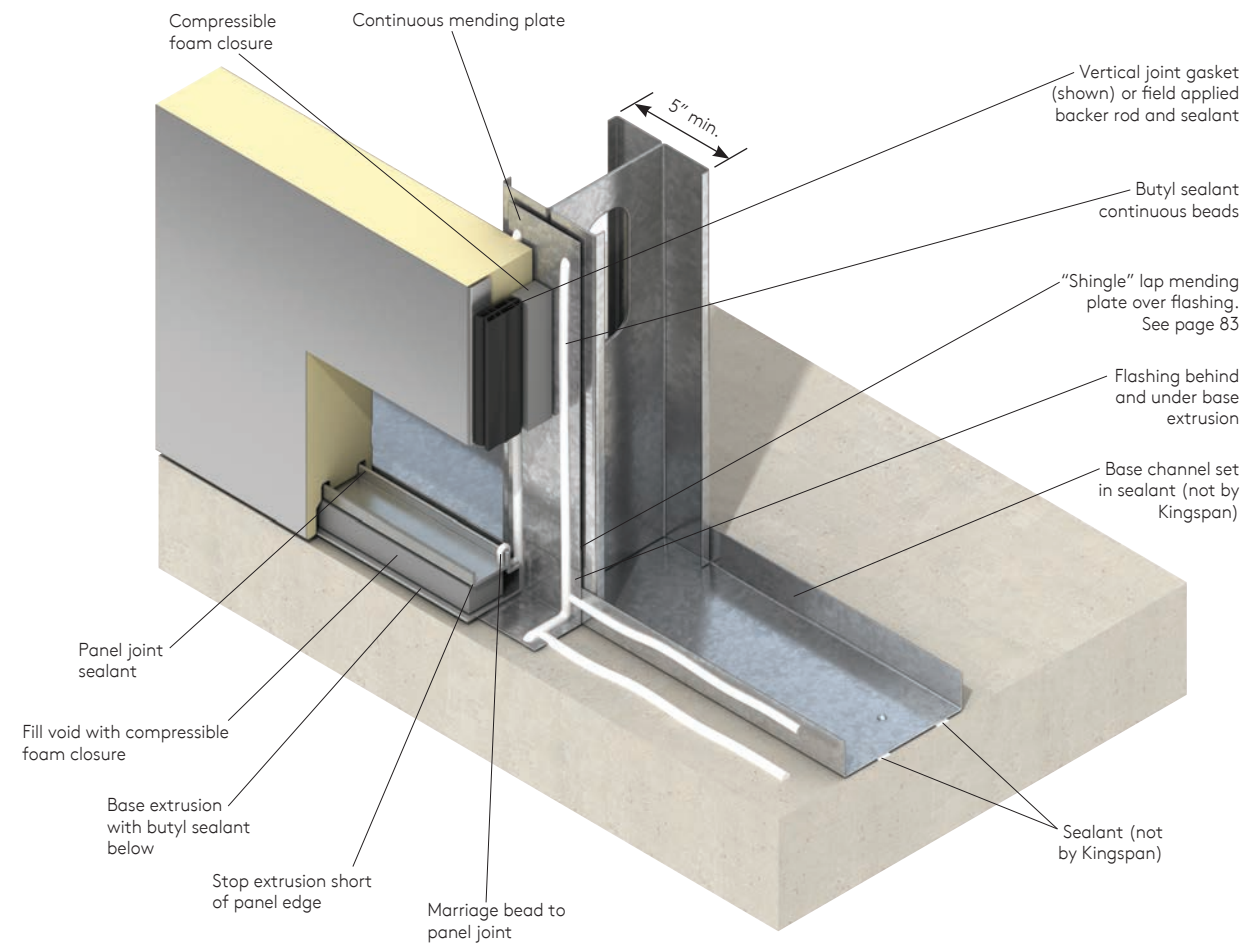
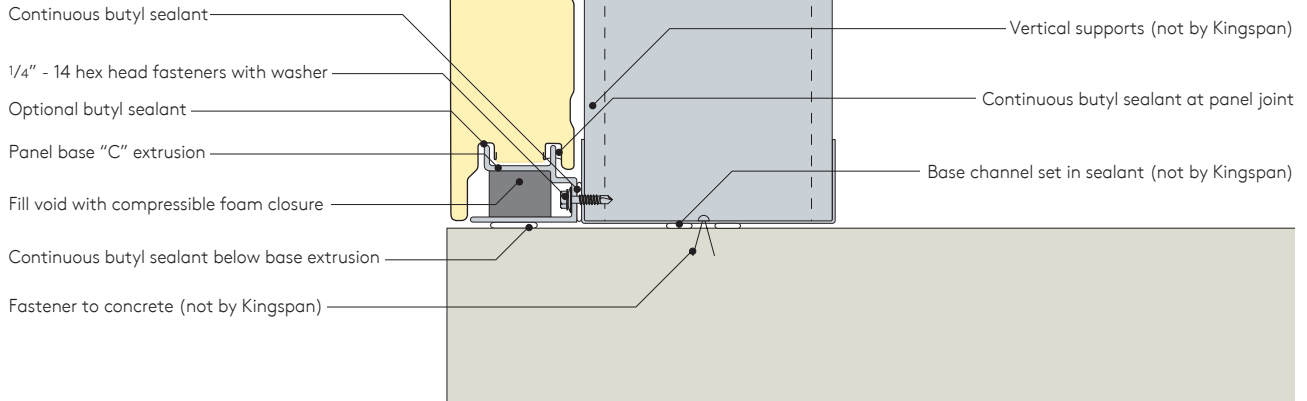

Trimless ends available with Granitstone®, Micro-Rib, Mini Micro-Rib and Optimo® panels.

# Horizontal Construction Details

## "J" Base Overhang Detail

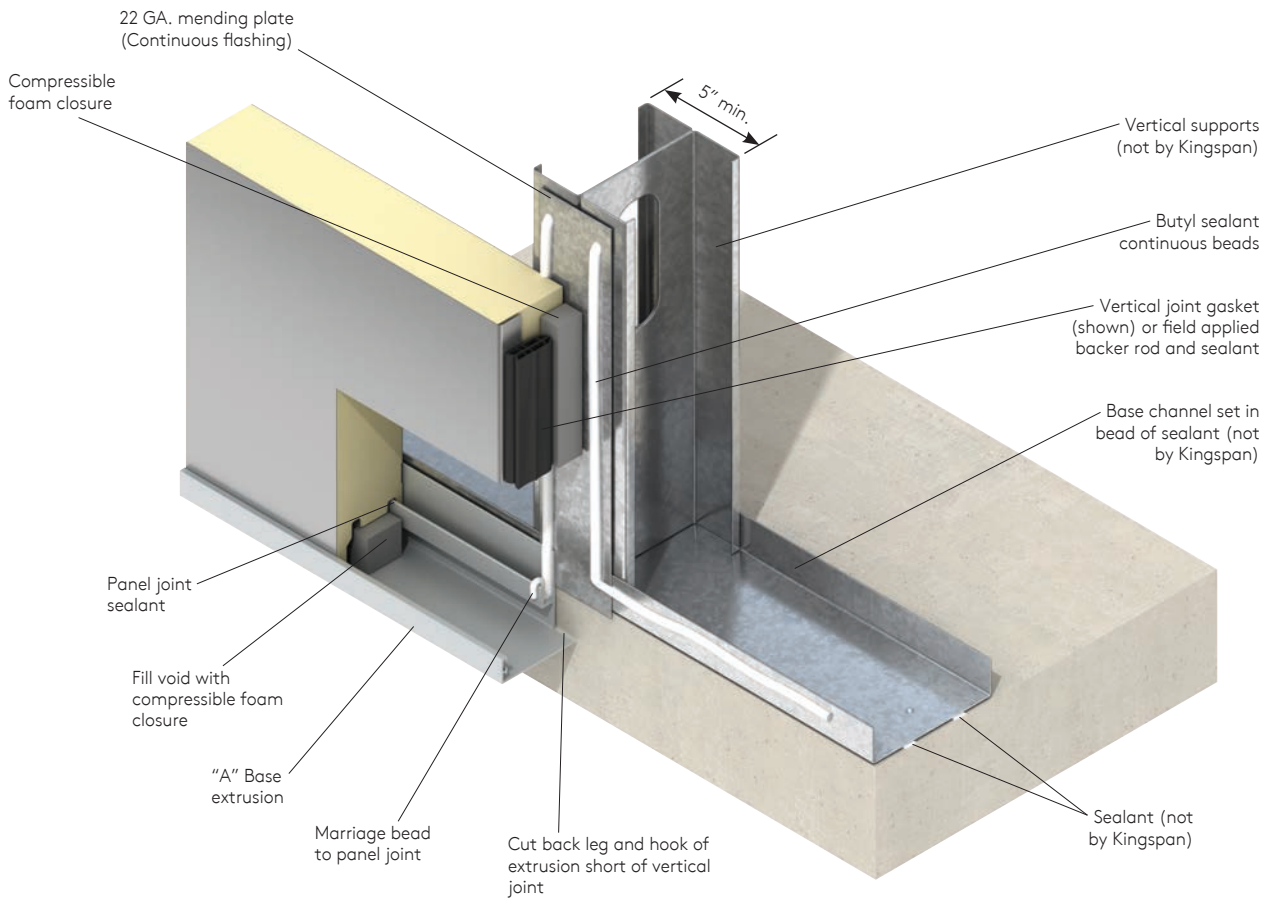
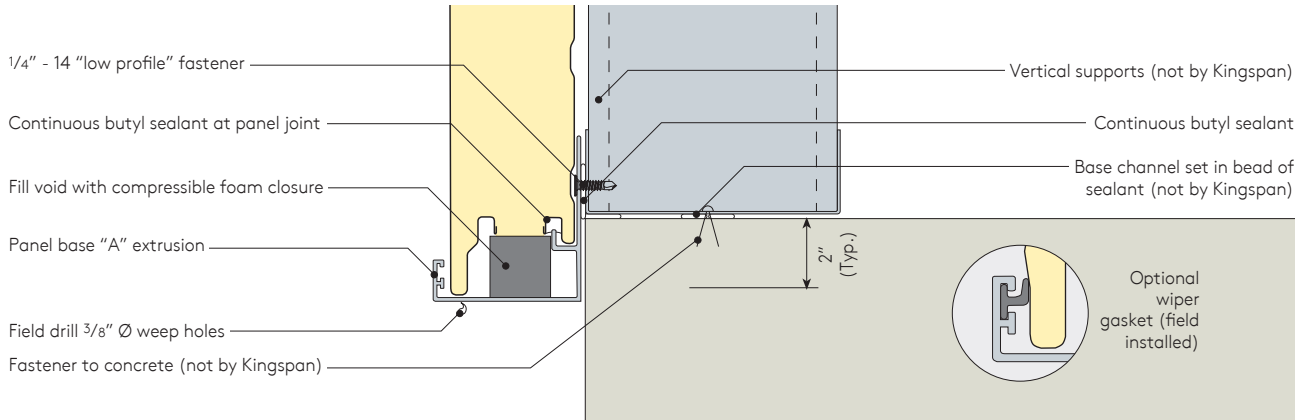

# Horizontal Construction Details

## Outside Corner with Flat Trim Detail

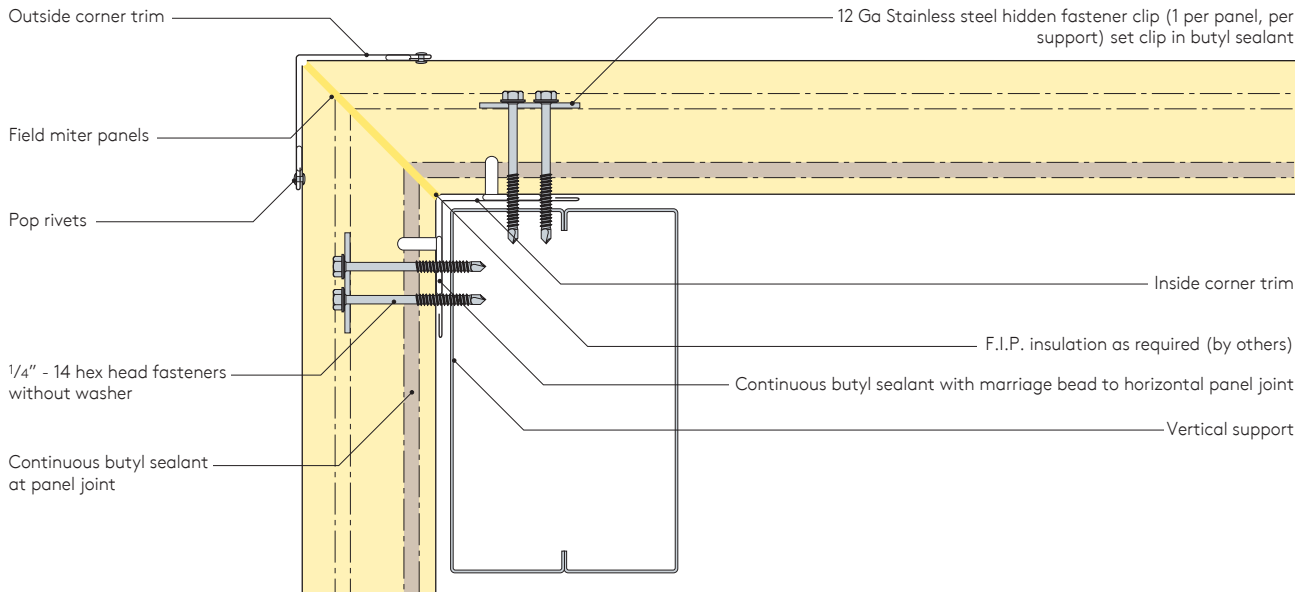

## Outside Corner - Factory Folded Detail

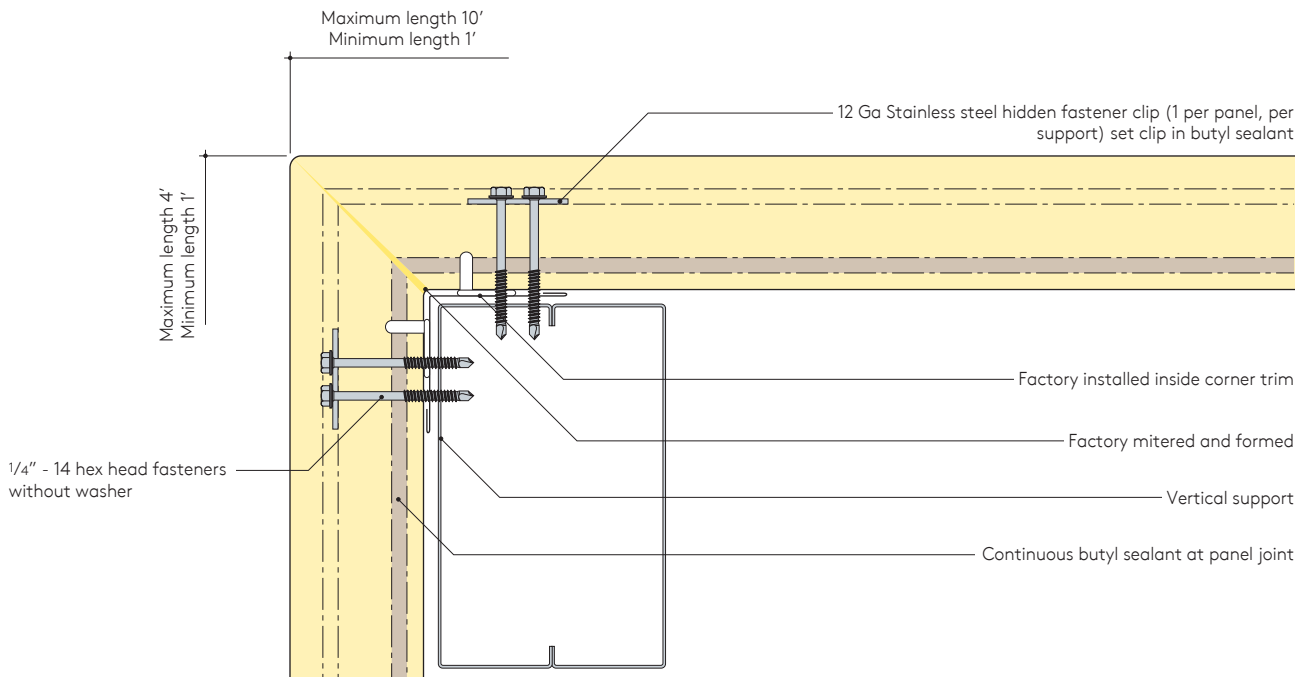

Factory folded corners and trimless ends available with Granitstone®, Micro-Rib, Mini Micro-Rib and Optimo® panels.

# Horizontal Construction Details

## Outside Corner with Extrusion Detail

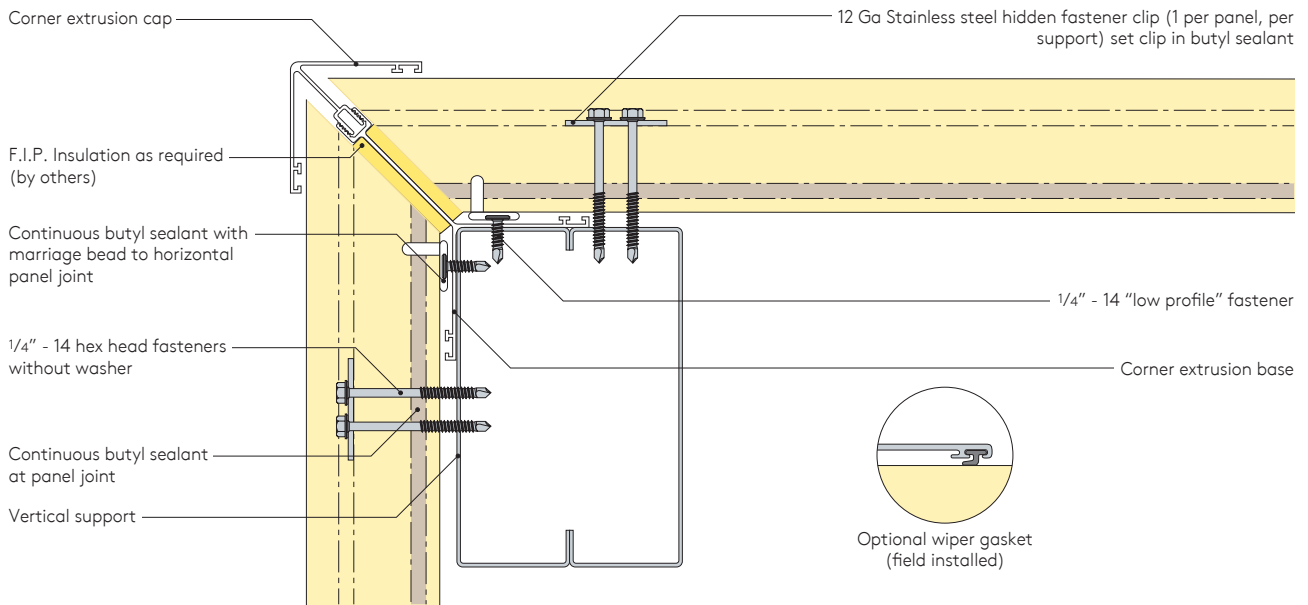

## Inside Corner with Flat Trim Detail

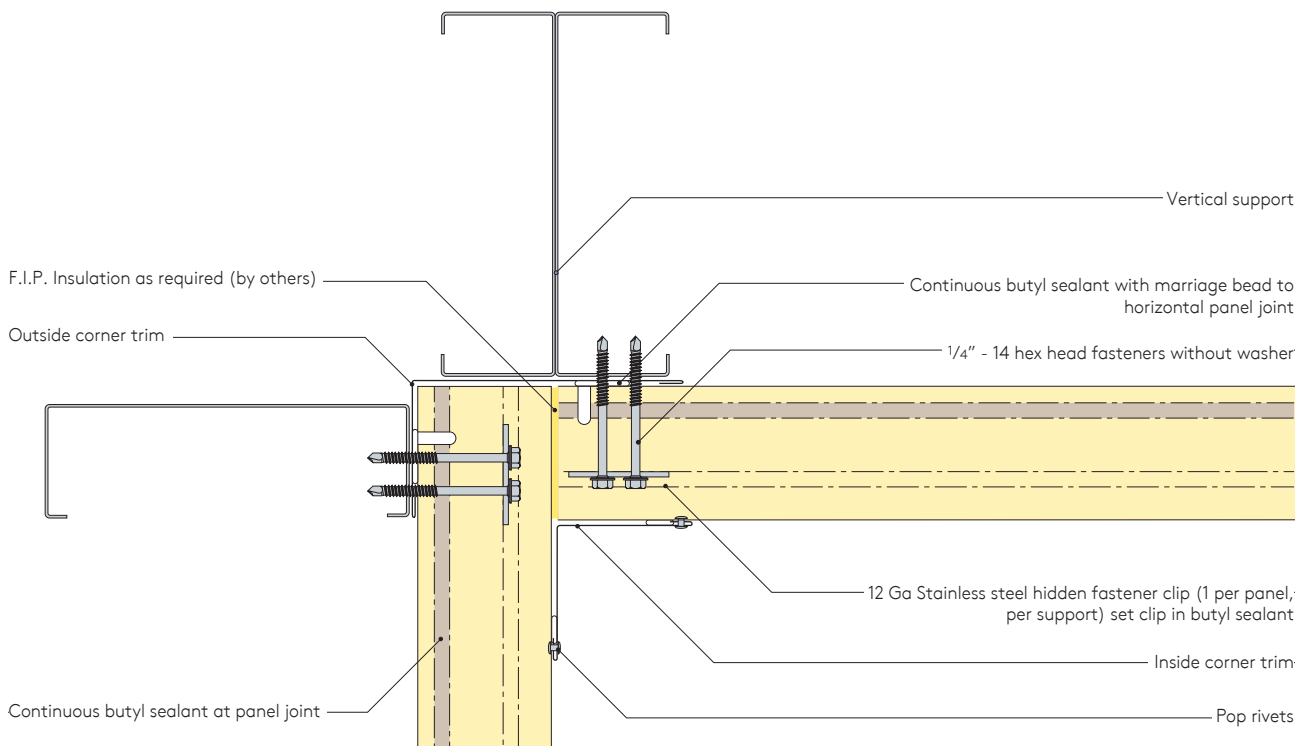

# Horizontal Construction Details

## Inside Corner with Gasket Detail

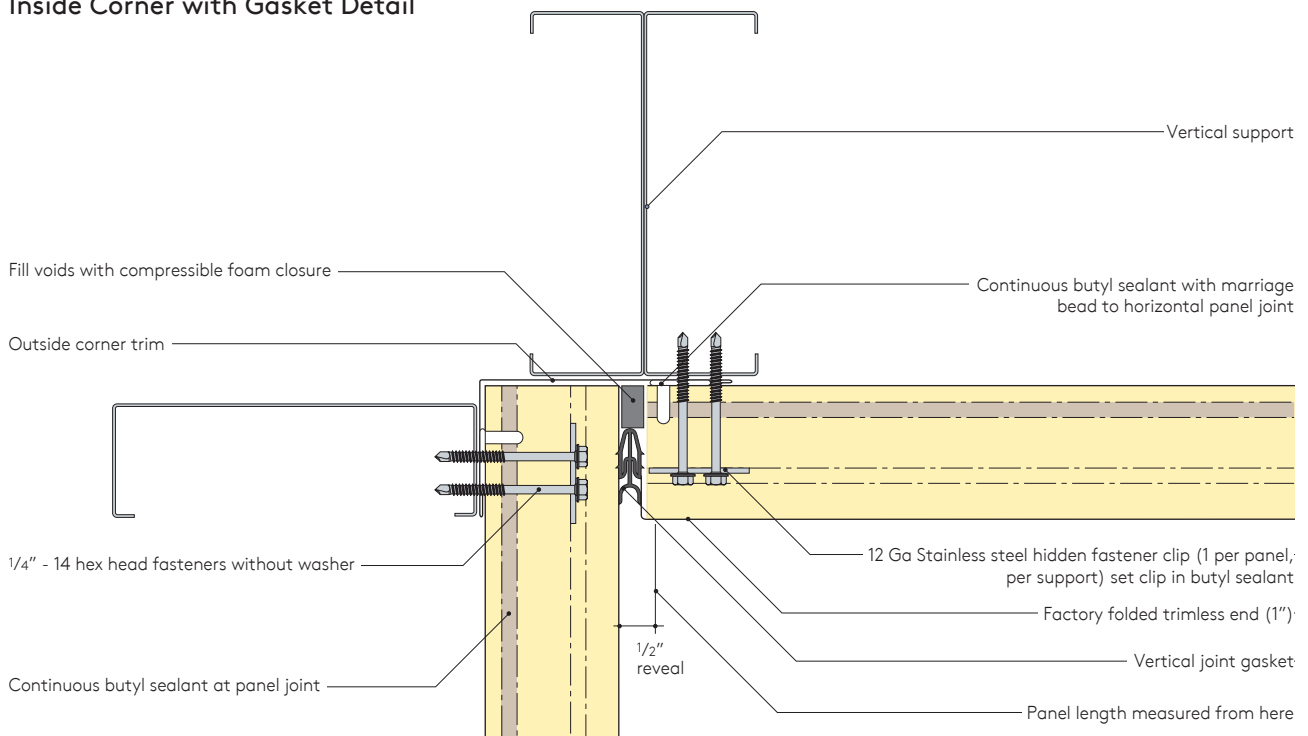

Trimless ends available with Granitstone®, Micro-Rib, Mini Micro-Rib and Optimo® panels.

## Inside Corner with Trim Detail

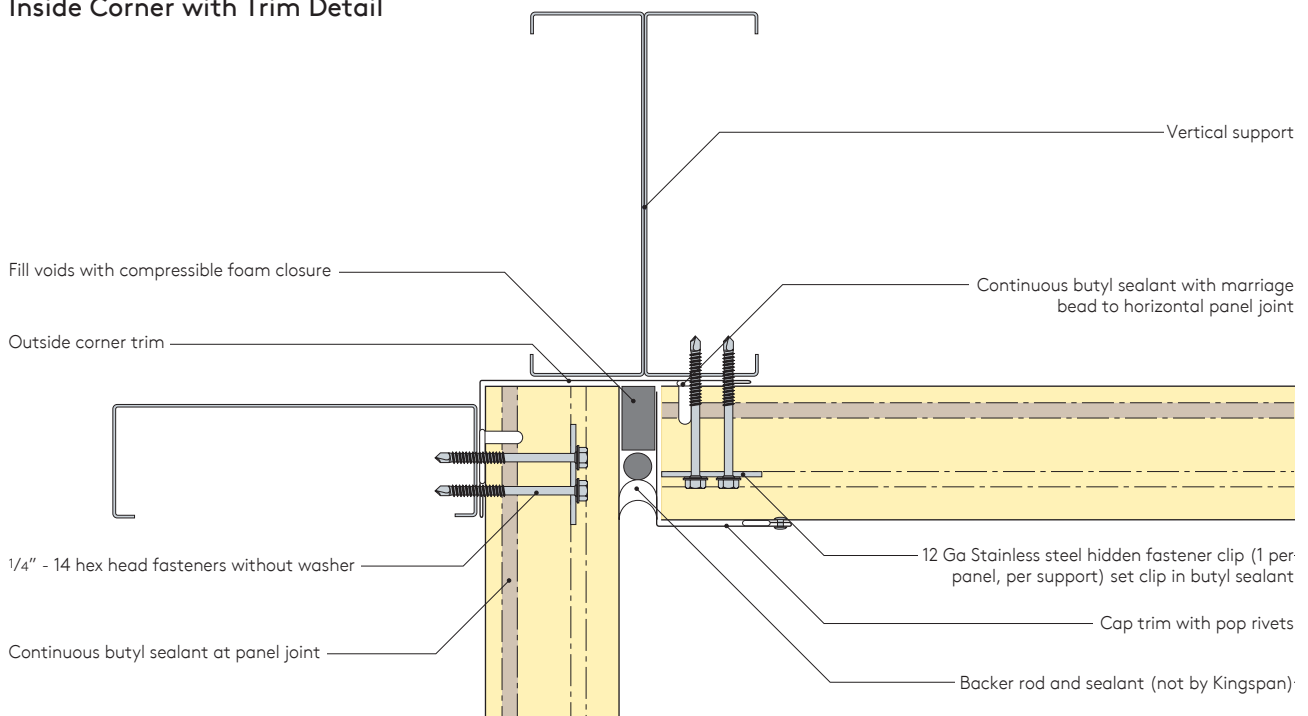



# Horizontal Construction Details

## Inside Corner with Jamb Extrusion Detail

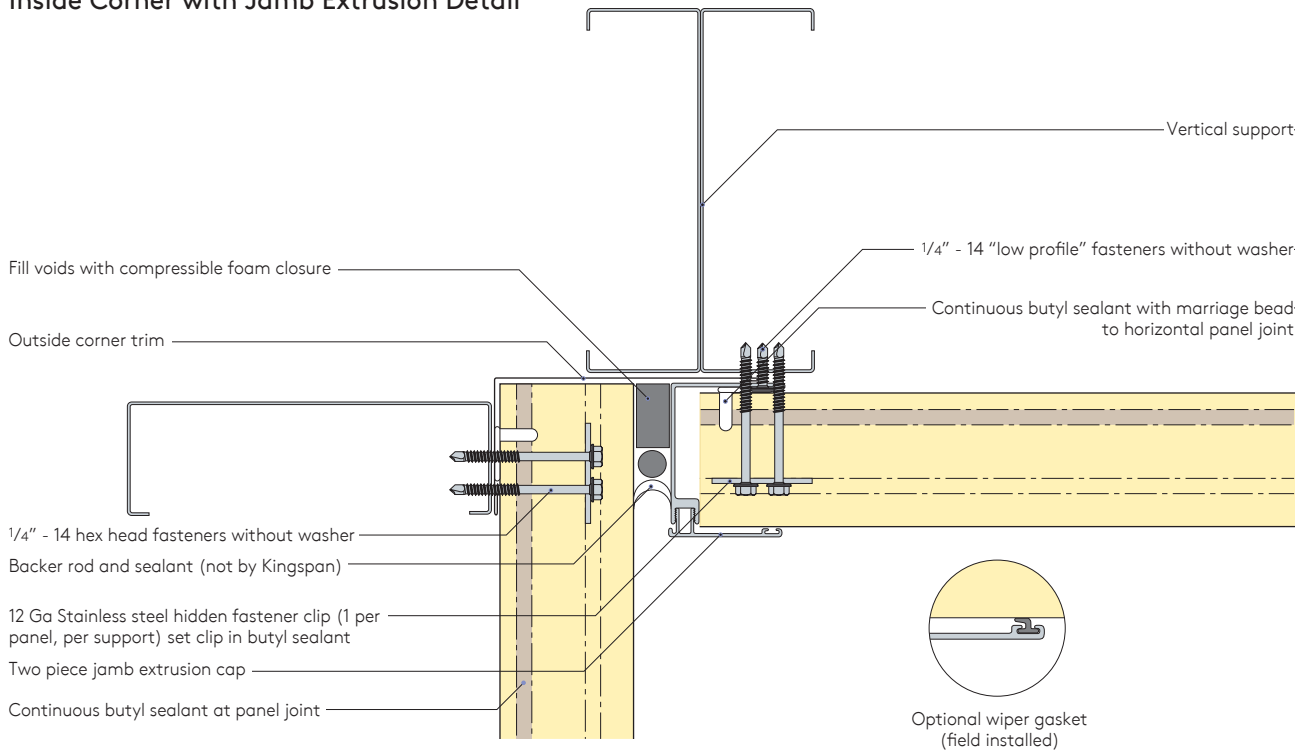

## Inside Corner with Extrusion Detail

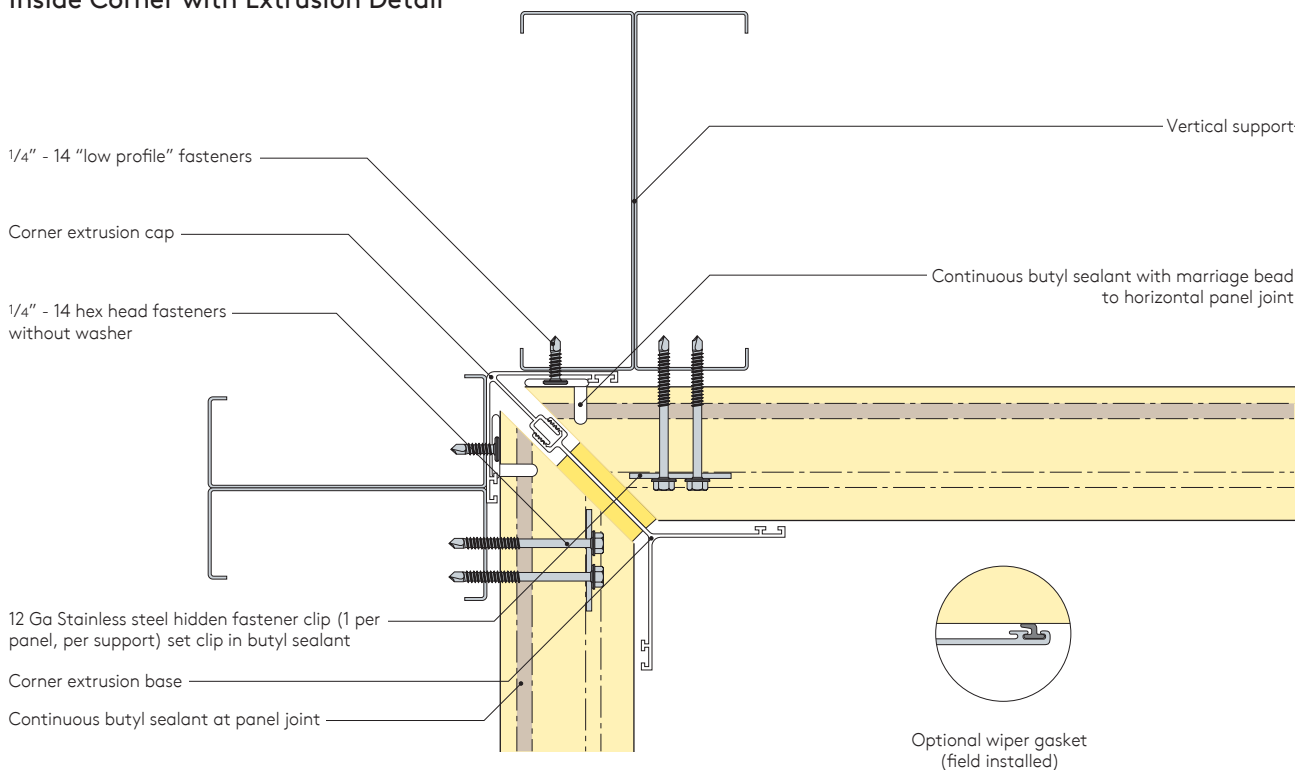

# Horizontal Construction Details

## Framed Opening Two Piece Head Detail

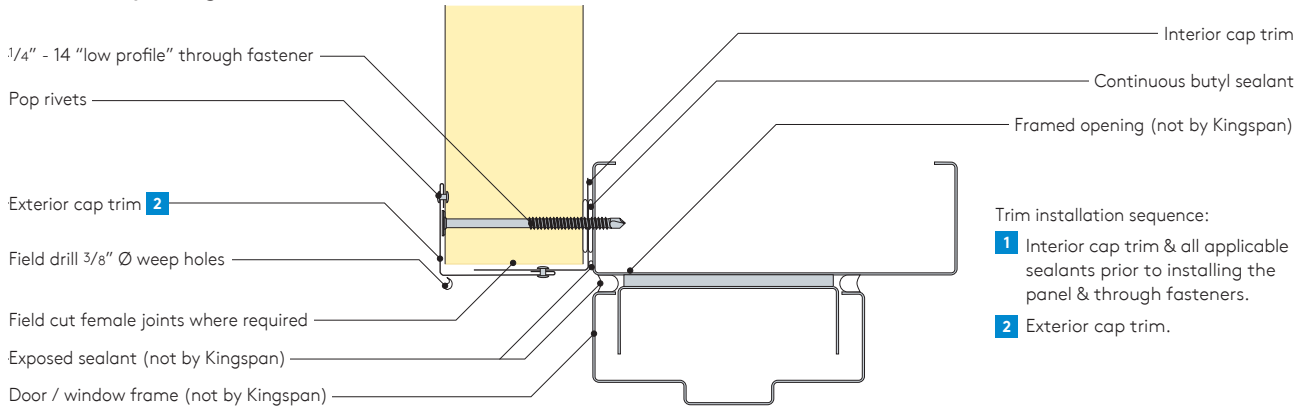

## Framed Opening Head with "Drip Edge" Detail

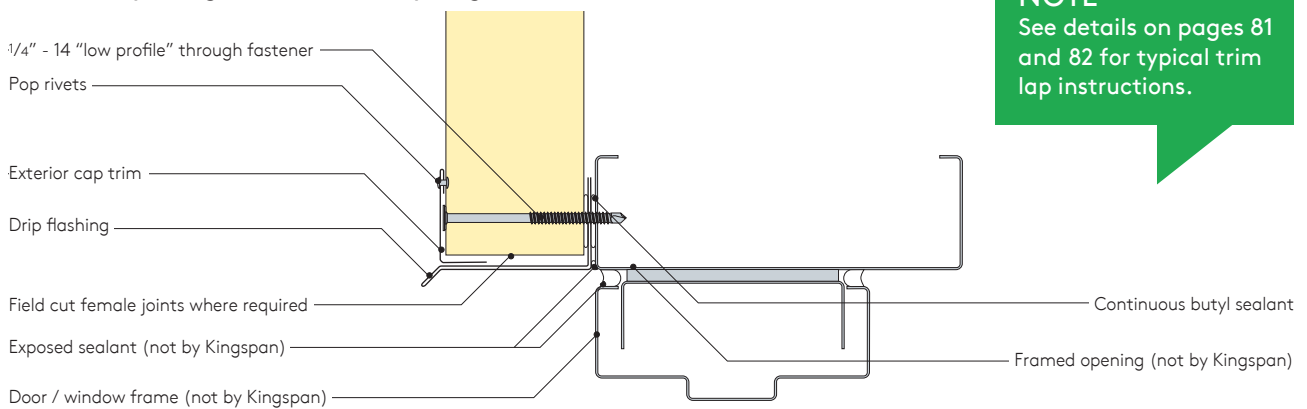

**NOTE**  
See details on pages 81 and 82 for typical trim lap instructions.

## Framed Opening Two Piece Jamb Detail

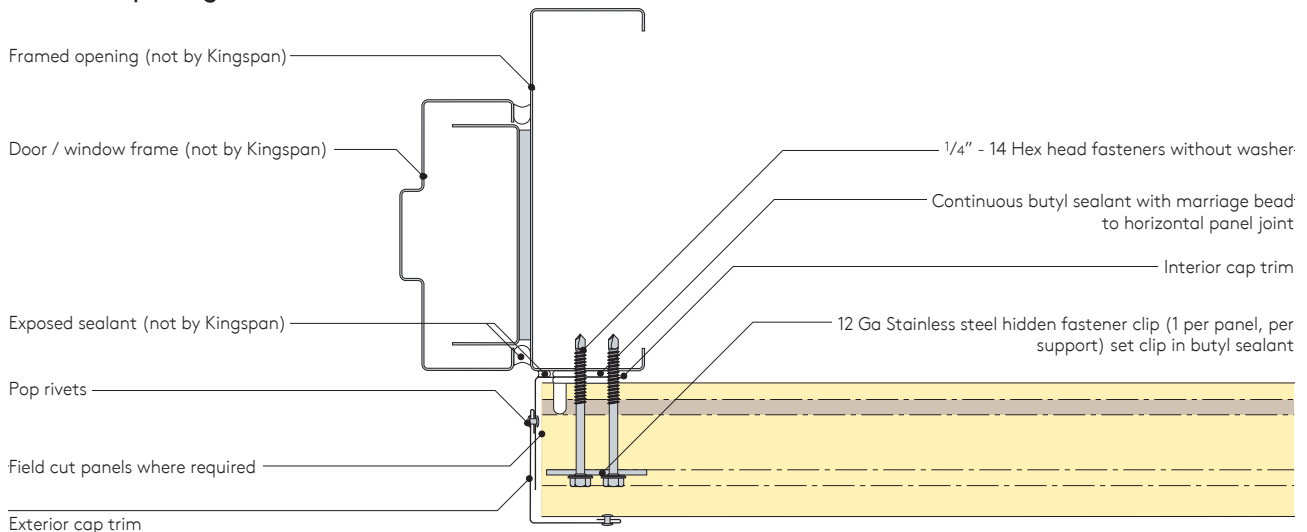

# Horizontal Construction Details

## Framed Opening One Piece Jamb Detail

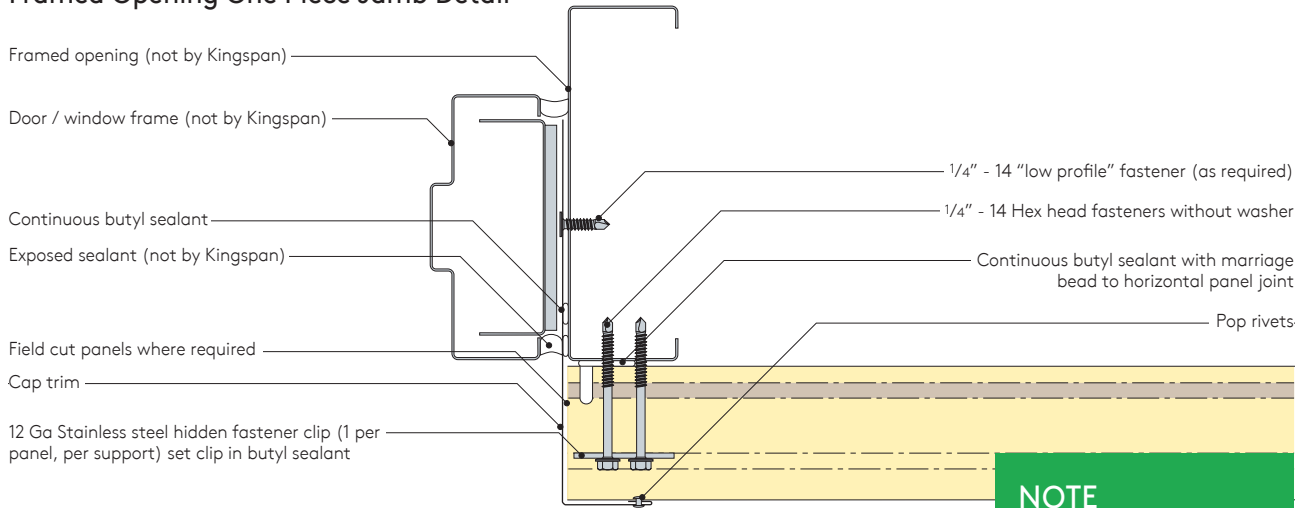

**NOTE**  
See details on pages 81 and 82 for typical trim lap instructions.

## Framed Opening One Piece Sill Detail

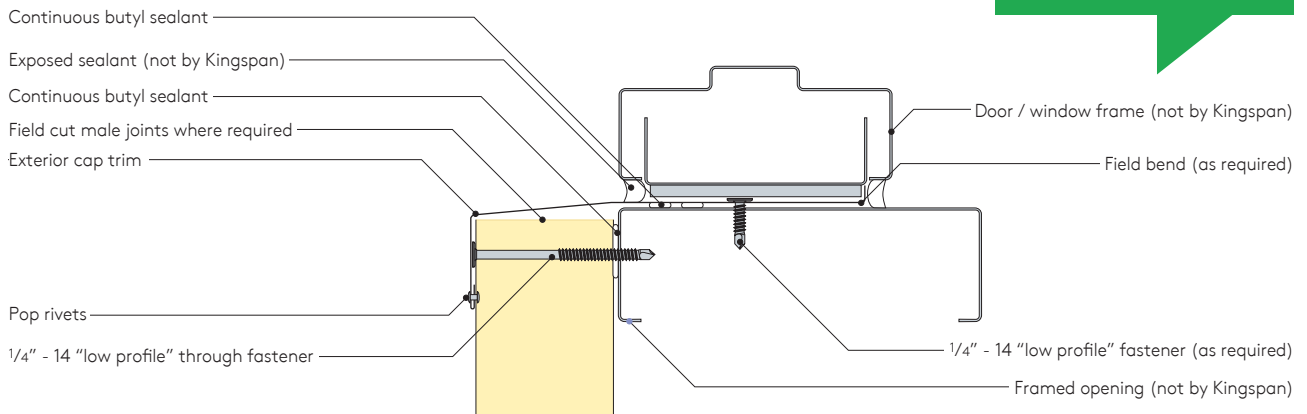

## Overhead Door Two Piece Header Detail

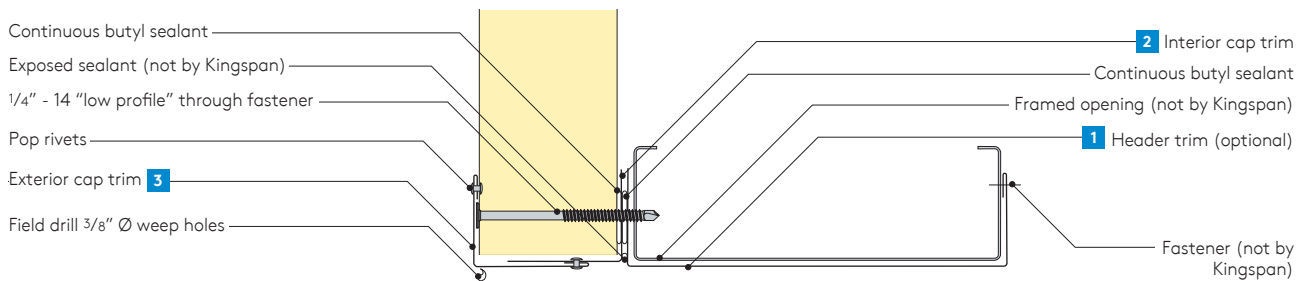

Trim installation sequence:

- 1** Install header trim (optional) & all applicable sealants.
- 2** Install interior cap trim & all applicable sealants prior to installing the panel and through fasteners.
- 3** Install exterior cap trim.

# Horizontal Construction Details

## Overhead Door Head with "Drip Edge" Detail

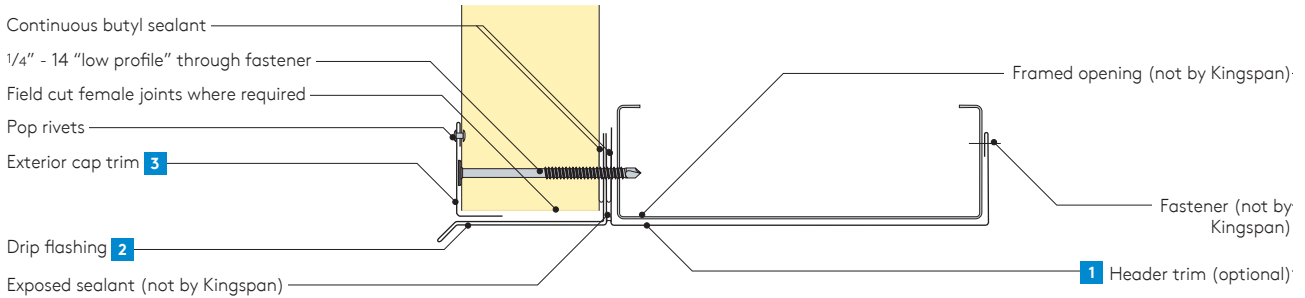

Trim installation sequence:

- 1** Install header trim (optional) & all applicable sealants.
- 2** Install drip flashing & all applicable sealants prior to installing the panel and through fasteners.
- 3** Install exterior cap trim.

**NOTE**  
See details on pages 81 and 82 for typical trim lap instructions.

## Overhead Door Two Piece Jamb Detail

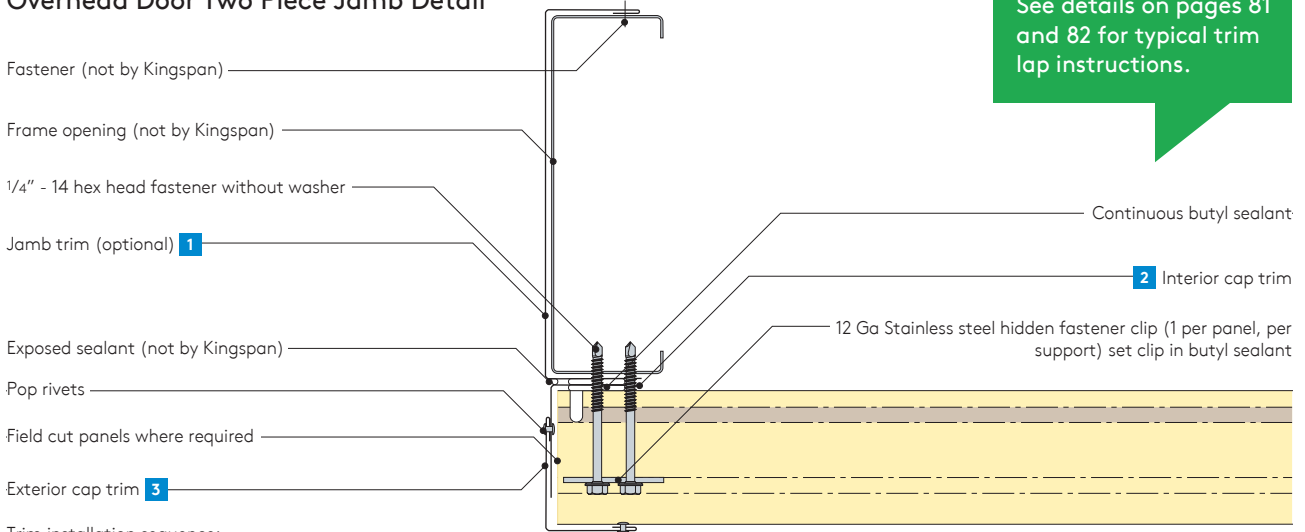

Trim installation sequence:

- 1** Install jamb trim (optional) & all applicable sealants.
- 2** Install interior cap trim & all applicable sealants prior to installing the panel and through fasteners.
- 3** Install exterior cap trim.

## Header with Extrusion Detail

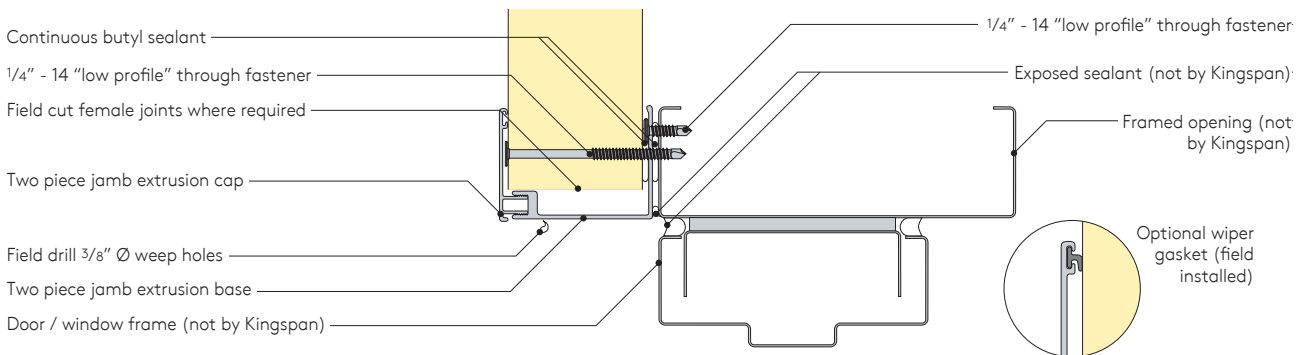

# Horizontal Construction Details

## Jamb with Extrusion Detail

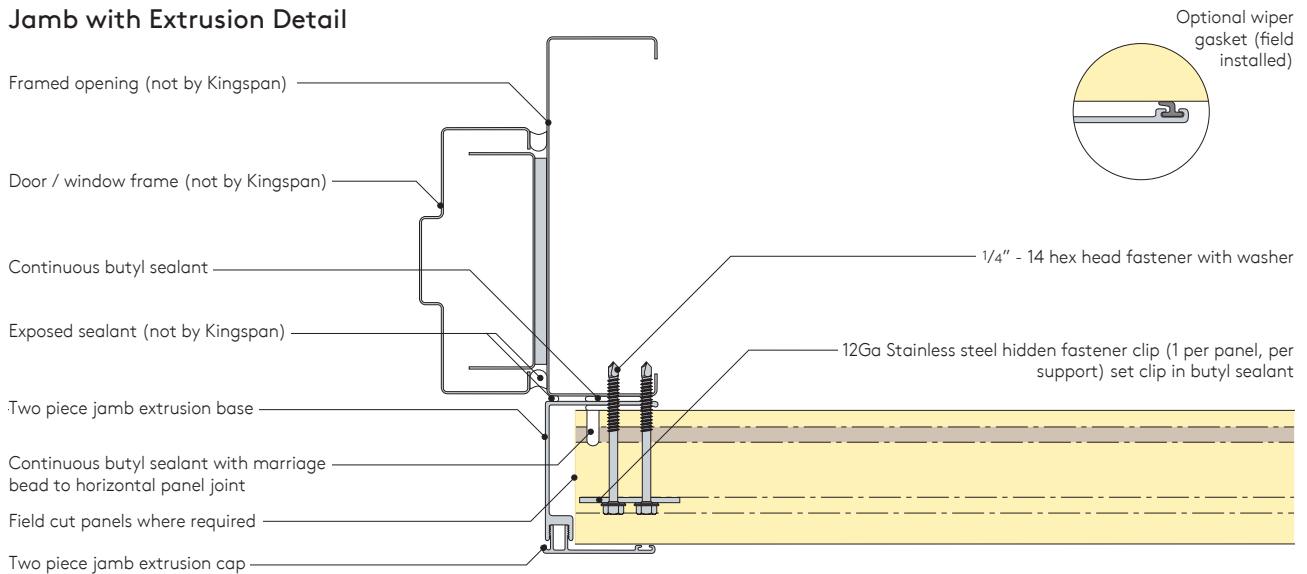

## Sill with Extrusion Detail

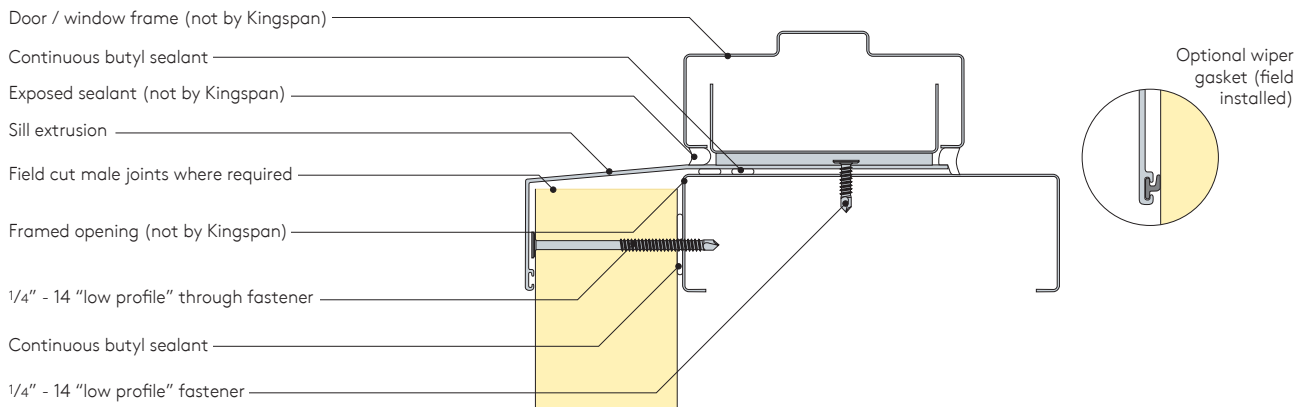

## Overhead Door Head with Extrusion Detail

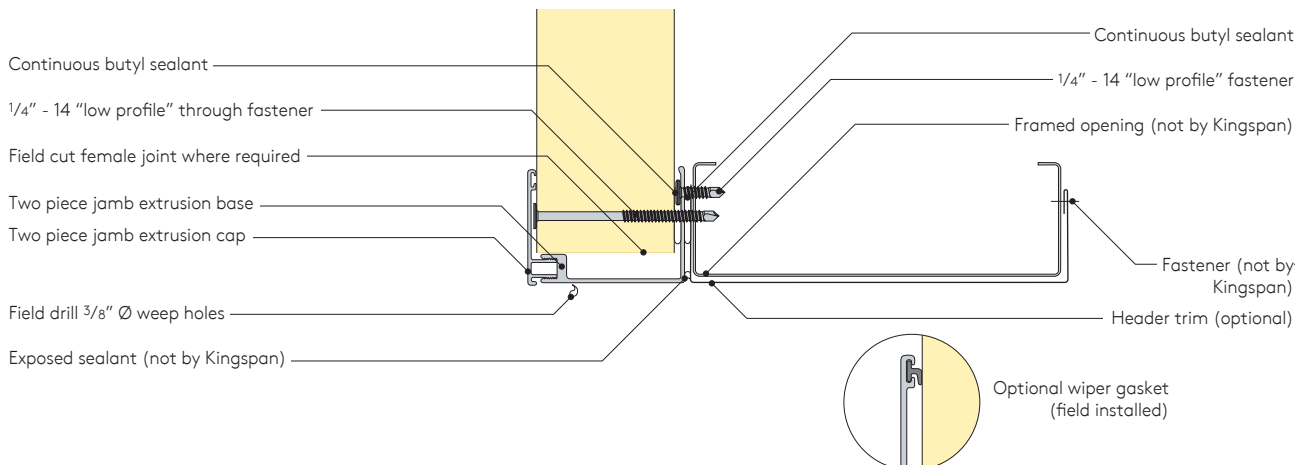

# Horizontal Construction Details

## Overhead Door Jamb with Extrusion Detail

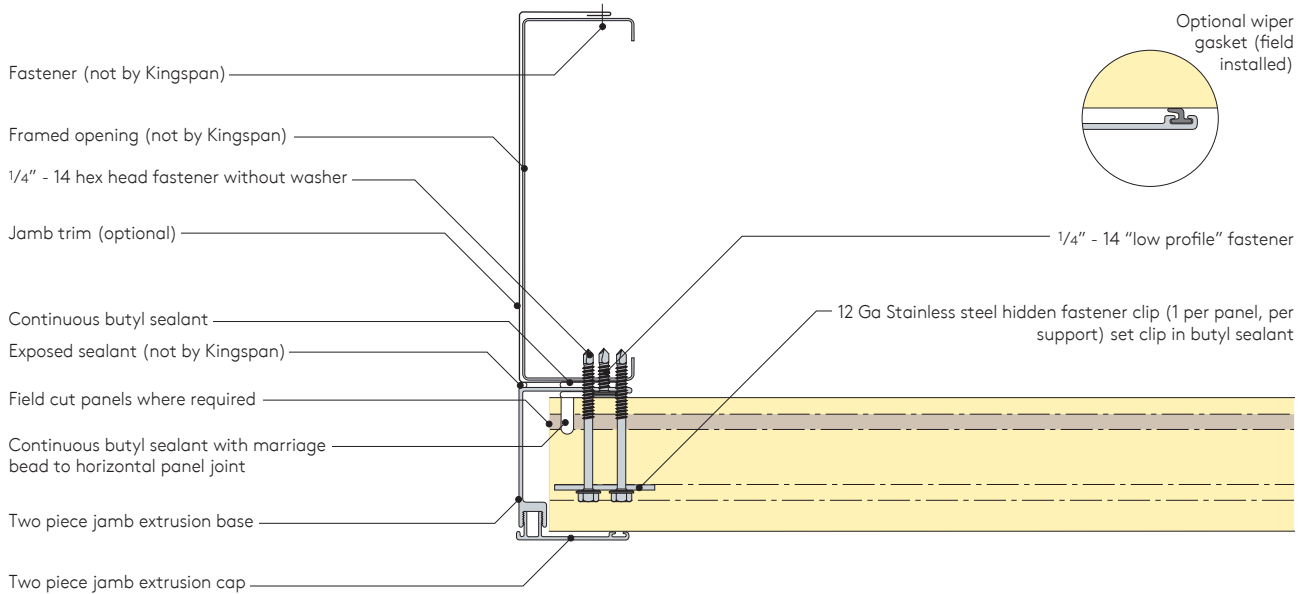

# Horizontal Construction Details

## Field Cut Parapet with Flush Trim Detail

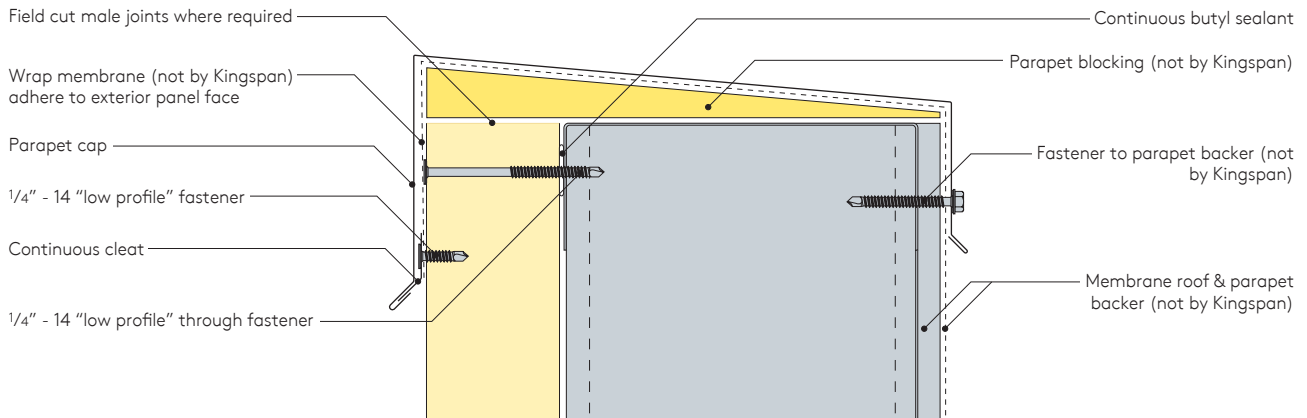

## Field Cut Parapet with Profiled Trim Detail

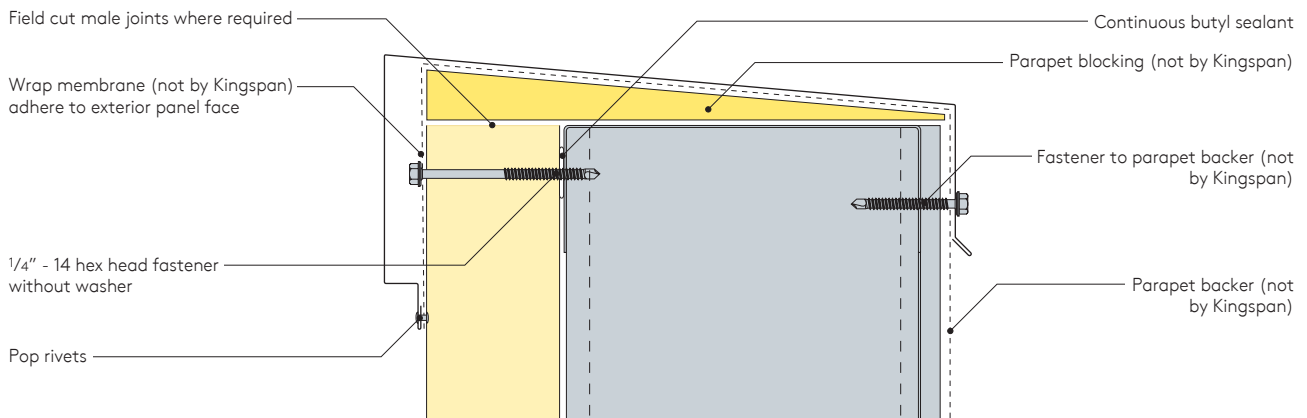

## Parapet with Flush Trim Detail

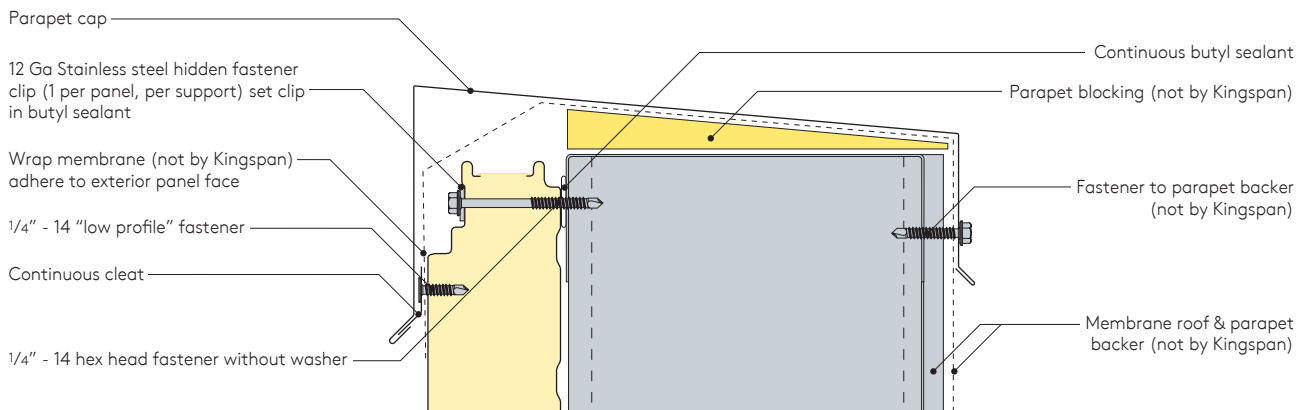

# Horizontal Construction Details

## Parapet with Profiled Trim Detail

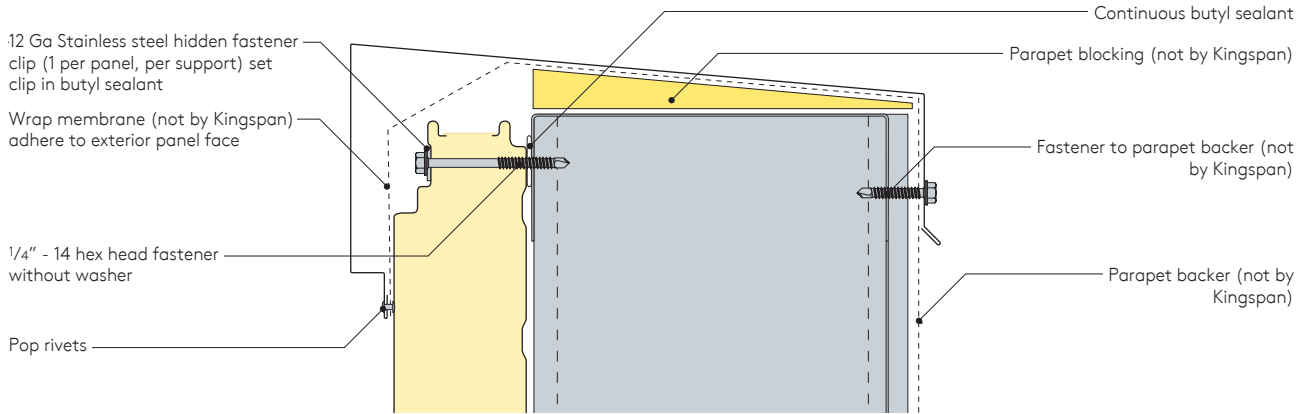

## Field Cut Parapet with Extrusion Detail

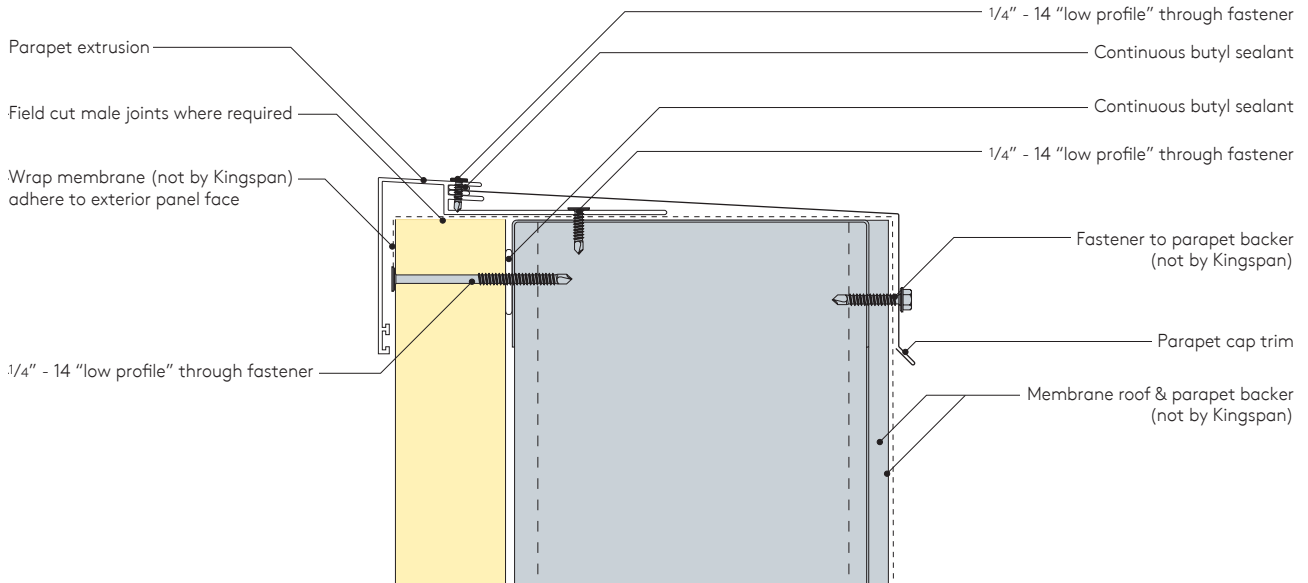



# Horizontal Construction Details

Trim End Lap Detail

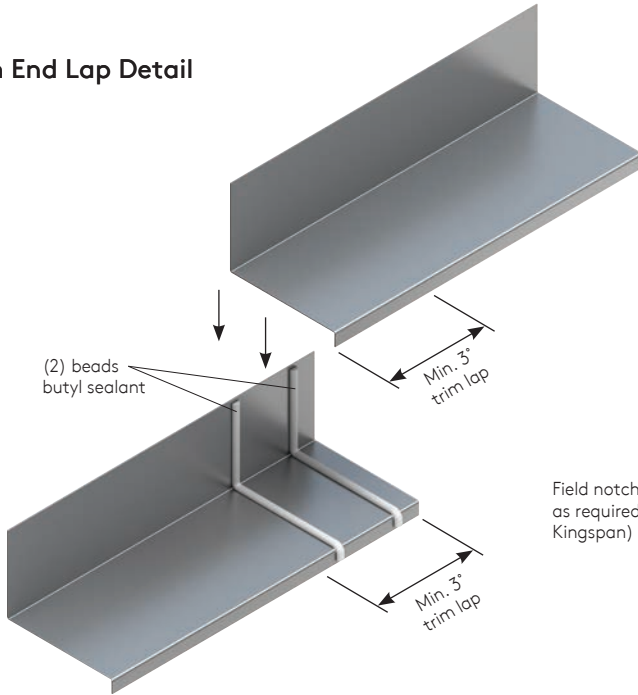

Field notch hem(s)  
as required (not by  
Kingspan)

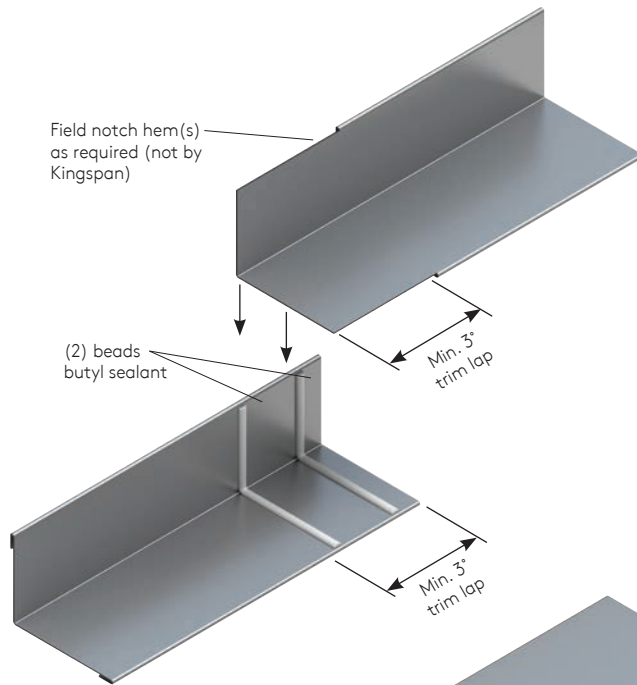

Trim Lap with Hem Detail

Trim End Lap with Lap Strip Detail

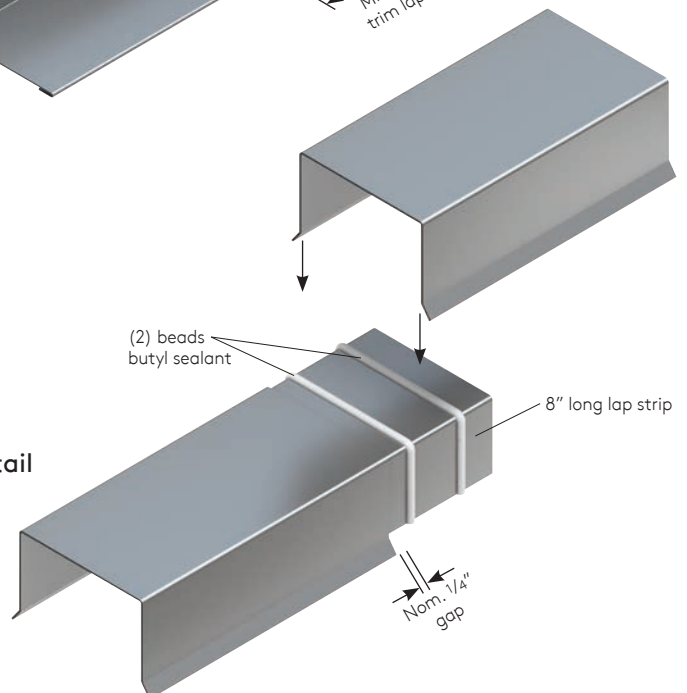

# Horizontal Construction Details

## Trim Lap at Framed Opening Detail

**NOTE**  
Weep holes should not to exceed 24" on center).

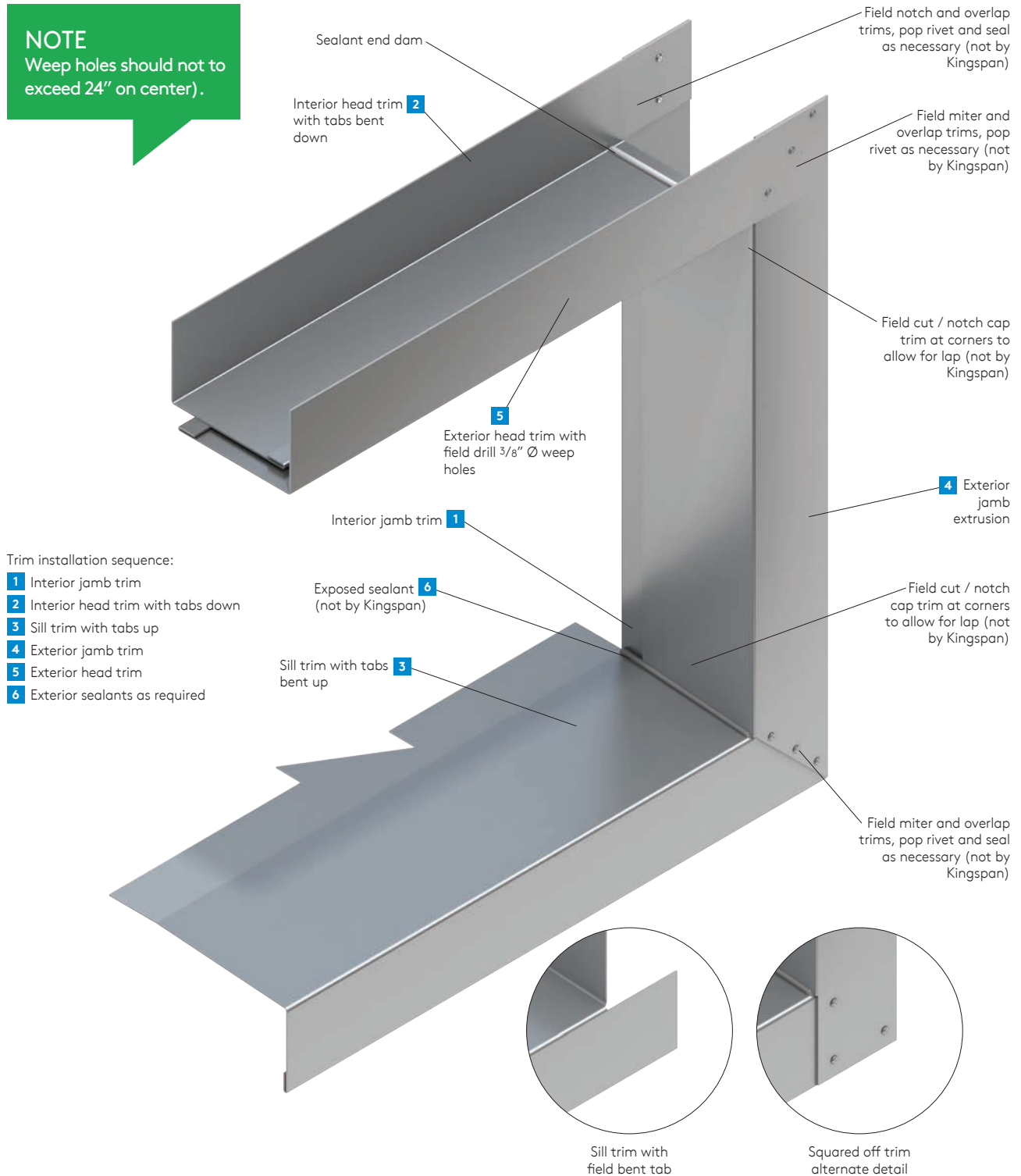

# Horizontal Construction Details

Mending Plate "Shingle" Lap Detail

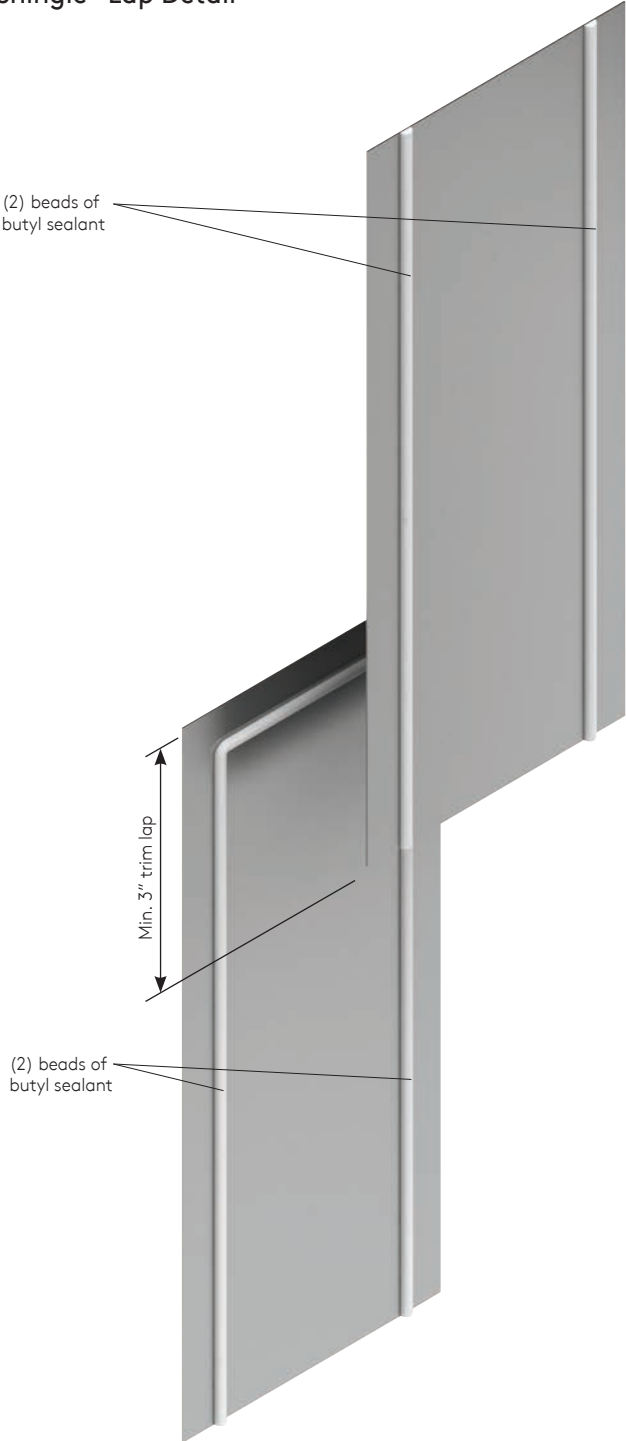

Installation

# Horizontal Construction Details

## Extrusions

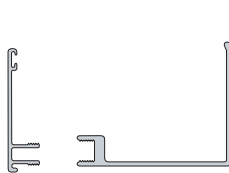

Jamb extrusion

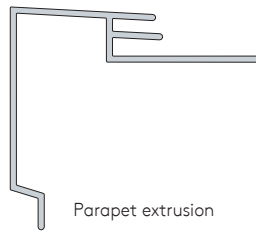

Parapet extrusion

### NOTE

For ease of installation, use a lubricant such as WD-40 or graphite when mating two piece extrusions.

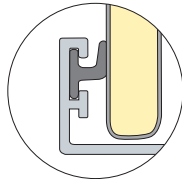

Optional wiper gasket  
(field installed)

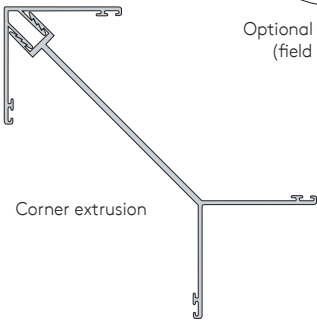

Corner extrusion

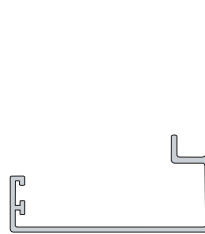

"J" Base extrusion

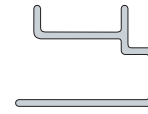

Base extrusion

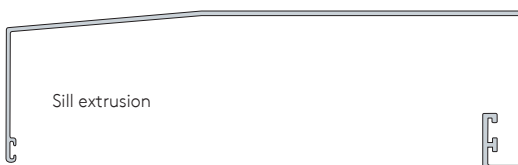

Sill extrusion

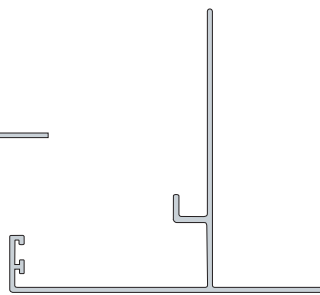

"J" Soffit extrusion

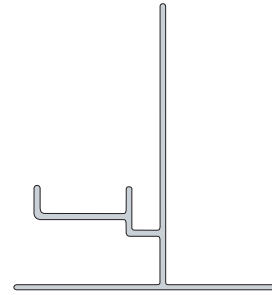

Soffit extrusion

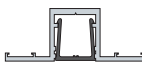

Flush insert

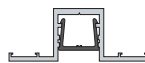

Recessed insert



EPDM insert

### Vertical joint extrusions

# Horizontal Construction Details

## NOTE

Aluminum extrusions may be used in lieu of press broke metal trims. Due to expansion and contraction, it is important to leave a gap of approximately 1/4" at the ends of each piece. Lap strips should be used to keep the extrusions properly aligned and weatherproof.

## Extrusions

Lap strip for two piece jamb extrusion

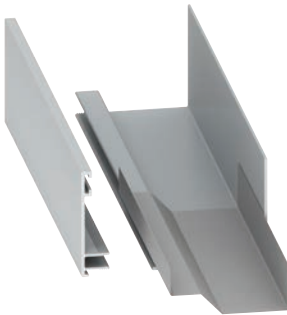

Lap strip for parapet extrusion

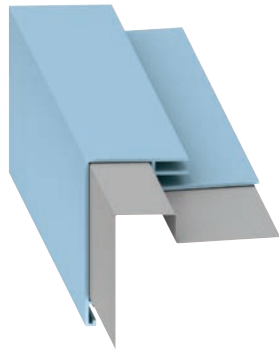

Lap strip for inside corner extrusion



Lap strip for outside corner extrusion



Lap strip for vertical top hat extrusion



Lap strip for base extrusion



Lap strip for "J" base extrusion

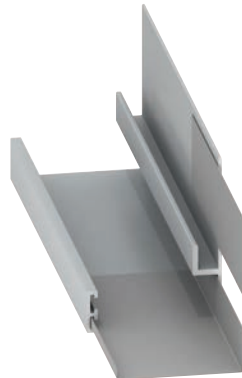

Lap strips for soffit extrusion



Lap strip for "J" soffit extrusion

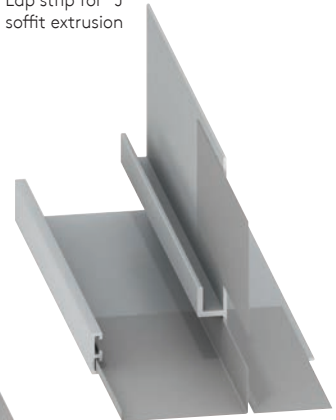

## NOTE

Lap strips for horizontal extrusions should be set in two rows of butyl sealant at each end. Extrusions should be field drilled with weep holes within 2" of the ends of the lap strips to allow adequate drainage.

# Horizontal Construction Details

## Extrusion at Framed Opening Detail

**NOTE**  
Weep holes should not to exceed 24" on center).

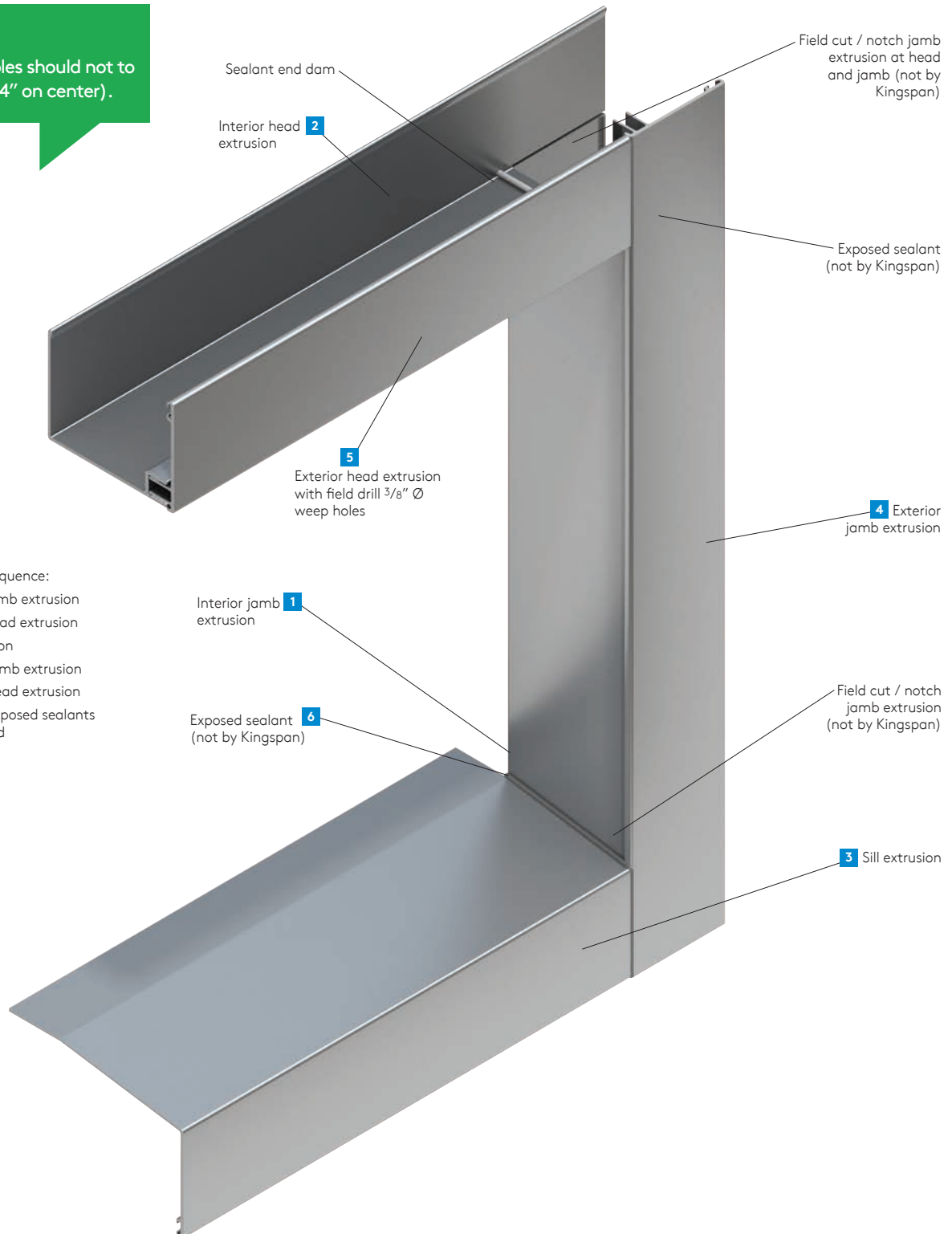

Installation sequence:

- 1 Interior jamb extrusion
- 2 Interior head extrusion
- 3 Sill extrusion
- 4 Exterior jamb extrusion
- 5 Exterior head extrusion
- 6 Exterior exposed sealants as required

# Materials, Tools and Hardware

## Tools and Sealants



Electric snips



Circular saw with fine tooth carbide blade



Power nibbler



Power drill



Drive bits and sockets



Expandable foam



Caulking gun

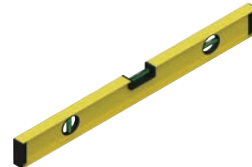

Laser or gravity levellers



Grip clamp

## Fastening Hardware



Primary fastener



Through fastener  
(primary fastener  
extended by 1")



Low profile fastener



Secondary fastener

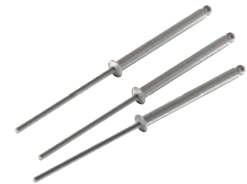

Rivet fastener



Hidden fastener  
wall panel clip



Knife and  
Scraper

---

# Contact Details

---

## USA

DeLand | FL  
T: 877-638-3266

Modesto | CA  
T: 800-377-5110

E: [info.NA@kingspanpanels.com](mailto:info.NA@kingspanpanels.com)  
[www.kingspanpanels.us](http://www.kingspanpanels.us)

---

## Canada

Caledon | ON  
T: 866-442-3594

Langley | BC  
T: 877-937-6562

E: [info.NA@kingspanpanels.com](mailto:info.NA@kingspanpanels.com)  
[www.kingspanpanels.ca](http://www.kingspanpanels.ca)

For the product offering in other markets please contact your local sales representative or visit [www.kingspanpanels.com](http://www.kingspanpanels.com)

Care has been taken to ensure that the contents of this publication are accurate, but Kingspan Limited and its subsidiary companies do not accept responsibility for errors or for information that is found to be misleading. Suggestions for, or description of, the end use or application of products or methods of working are for information only and Kingspan Limited and its subsidiaries accept no liability in respect thereof.

